

Product depths offered are listed below the product name. BCI® 60 and 90 deep depths are available from White City. Some products may not be available in all markets. Contact your Boise Cascade EWP representative for availability. BCI® and Versa-Lam® products shall be installed in dry-use applications only, per their respective ICC ESR evaluation reports.

WARNING

THE FOLLOWING USES ARE NOT ALLOWED

<p>DO NOT notch or drill beams without prior approval from Boise Cascade EWP Engineering.</p>	<p>DO NOT cut beyond inside edge of bearing.</p>	<p>DO NOT support joist on web.</p>
<p>DO NOT cut holes too close to supports or to each other.</p> <p>Refer to hole location and sizing chart for size and spacing.</p>	<p>DO NOT nail closer than 1/2" from end of joist.</p> <p>DO NOT use 16d common nails.</p> <p>Use 8d nails or 10d/16d box nails.</p>	<p>DO NOT cut or notch flange.</p> <p>See roof and floor details, this sheet, for allowed cutting of flange.</p>
<p>DO NOT walk on joist until proper bracing is in place.</p> <p>DO NOT load joist beyond design capacity.</p> <p>DO NOT stack building materials on unbraced joists.</p>	<p>DO NOT install tongue of floor sheathing flush with either 1" or 1/16" thick Boise Cascade® rimboard (tongue OK with 1/8" and thicker Boise Cascade® rimboard).</p> <p>T&G Floor Sheathing</p> <p>Trim tongue of 1/8" sheathing regardless of rimboard thickness.</p> <p>1" or 1/16" thick Boise Cascade® rimboard</p> <p>Trim tongue flush with rim.</p>	<p>DO NOT hammer on web unless removing knockout holes.</p> <p>DO NOT hammer on flange.</p>

SAFETY WARNING

DO NOT ALLOW WORKERS ON BCI® JOISTS UNTIL ALL HANGERS, BCI® RIM JOISTS, RIM BOARDS, BCI® BLOCKING PANELS, X-BRACING AND TEMPORARY 1x4 STRUT LINES ARE INSTALLED AS SPECIFIED BELOW. SERIOUS ACCIDENTS CAN RESULT FROM INSUFFICIENT ATTENTION TO PROPER BRACING DURING CONSTRUCTION. ACCIDENTS CAN BE AVOIDED UNDER NORMAL CONDITIONS BY FOLLOWING THESE GUIDELINES:

- Build a braced end wall at the end of the bay, or permanently install the first eight feet of BCI® Joists and the first course of sheathing. As an alternate, temporary sheathing may be nailed to the first four feet of BCI® Joists at the end of the bay.
- All hangers, BCI® rim joists, rim boards, BCI® blocking panels, and x-bracing must be completely installed and properly nailed as each BCI® Joist is set.

- Install temporary 1x4 strut lines at no more than eight feet on center as additional BCI® Joists are set. Nail the strut lines to the sheathed area, or braced end wall, and to each BCI® Joist with two 8d nails.
- The ends of cantilevers must be temporarily secured by strut lines on both the top and bottom flanges.
- Straighten the BCI® Joists to within 1/2 inch of true alignment before attaching strut lines and sheathing.
- Remove the temporary strut lines only as required to install the permanent sheathing.
- Failure to install temporary bracing may result in sideways buckling or roll-over under light construction loads.
- Do not stack construction materials (sheathing, drywall, etc.) in the middle of BCI® Joist spans, contact Boise Cascade EWP Engineering for proper storage and shoring information.

BUILDING CODE EVALUATION REPORTS:

BCI® JOISTS BLDG CODE EVALUATION REPORTS
- ICC-ES®/APA® ESR-1336 (IBC, IRC)

VERSA-LAM® LVL BLDG CODE EVALUATION REPORTS
- ICC-ES®/APA® ESR-1040 (IBC, IRC)

About Floor Performance

Homeowner's expectations and opinions vary greatly due to the subjective nature of rating a new floor. Communication with the ultimate end user to determine their expectation is critical. **Vibration** is usually the cause of most complaints. Installing lateral bridging may help; however, squeaks may occur if not installed properly. Spacing the joists closer together does little to affect the perception of the floor's performance. The most common methods used to increase the performance and reduce vibration of wood floor systems is to

increase the joist depth, limit joist deflections, glue and screw a thicker, tongue-and-groove subfloor, install the joists vertically plumb with level-bearing supports, and install a direct-attached ceiling to the bottom flanges of the joists.

The floor span tables listed below offer three very different performance options, based on performance requirements of the homeowner.

Joist Depth	BCI® Joist Series	★★★ THREE STAR ★★★					★★★★ FOUR STAR ★★★★★					CAUTION	★ MINIMUM STIFFNESS ALLOWED BY CODE ★					CAUTION			
		Live Load deflection limited to L/480: The common industry and design community standard for residential floor joists, 33% stiffer than L/360 code minimum. However, floor performance may still be an issue in certain applications, especially with 9½" and 11⅞" deep joists without a direct-attached ceiling.					Live Load deflection limited to L/960+: In addition to providing a floor that is 100% stiffer than the three star floor , field experience has been incorporated into the values to provide a floor with a premium performance level for the more discriminating homeowner.					Live Load deflection limited to L/360: Floors that meet the minimum building code L/360 criteria are structurally sound to carry the specified loads; however, there is a much higher risk of floor performance issues. This table should only be used for applications where floor performance is not a concern.									
		12" o.c.	16" o.c.	19.2" o.c.	24" o.c.	32" o.c.	12" o.c.	16" o.c.	19.2" o.c.	24" o.c.	32" o.c.	12" o.c.	16" o.c.	19.2" o.c.	24" o.c.	32" o.c.	12" o.c.	16" o.c.	19.2" o.c.	24" o.c.	32" o.c.
9½"	4500s 1.8	16'-11"	15'-6"	14'-8"	13'-7"	11'-9"	11'-6"	11'-6"	10'-0"	10'-0"	9'-7"	18'-9"	16'-8"	15'-3"	13'-7"	11'-9"	19'-4"	17'-9"	16'-4"	14'-7"	12'-5"
	5000s 1.8	17'-6"	16'-0"	15'-2"	14'-1"	12'-5"	11'-6"	11'-6"	10'-0"	10'-0"	9'-11"	19'-4"	17'-9"	16'-4"	14'-7"	12'-5"	20'-2"	18'-5"	17'-5"	15'-9"	13'-8"
	6000s 1.8	18'-2"	16'-8"	15'-8"	14'-8"	13'-4"	11'-6"	11'-6"	10'-0"	10'-0"	10'-0"	20'-2"	18'-5"	17'-5"	15'-9"	13'-8"	20'-8"	18'-11"	17'-10"	16'-7"	14'-3"
	6500s 1.8	18'-8"	17'-1"	16'-1"	15'-0"	13'-8"	11'-6"	11'-6"	10'-0"	10'-0"	10'-0"	20'-8"	18'-11"	17'-10"	16'-7"	14'-3"	21'-10"	18'-11"	17'-3"	15'-5"	13'-4"
11⅞"	4500s 1.8	20'-0"	18'-4"	17'-3"	15'-5"	13'-4"	15'-6"	14'-3"	13'-5"	12'-6"	11-4"	21'-10"	18'-11"	17'-3"	15'-5"	13'-4"	23'-0"	20'-4"	18'-6"	16'-7"	13'-4"
	5000s 1.8	20'-9"	19'-8"	17'-11"	16'-7"	13'-4"	15'-6"	14'-9"	13'-11"	12'-11"	11'-9"	23'-0"	20'-4"	18'-6"	16'-7"	13'-4"	23'-10"	21'-10"	20'-0"	17'-11"	14'-10"
	6000s 1.8	21'-7"	19'-8"	18'-7"	17'-4"	14'-10"	15'-6"	15'-4"	14'-5"	13'-5"	12'-1"	23'-10"	21'-10"	20'-0"	17'-11"	14'-10"	24'-6"	22'-5"	21'-1"	18'-10"	14'-10"
	6500s 1.8	22'-2"	20'-3"	19'-2"	17'-10"	14'-10"	16'-0"	15'-10"	14'-11"	13'-10"	12'-7"	24'-6"	22'-5"	21'-1"	18'-10"	14'-10"	26'-1"	23'-10"	22'-6"	21'-0"	16'-4"
	60s 2.0	23'-7"	21'-6"	20'-4"	18'-11"	16'-4"	18'-0"	16'-9"	15'-9"	14'-8"	13'-3"	26'-1"	23'-10"	22'-6"	21'-0"	16'-4"	29'-5"	26'-10"	25'-3"	23'-6"	19'-4"
	90s 2.0	26'-7"	24'-3"	22'-10"	21'-3"	19'-4"	19'-0"	18'-10"	17'-8"	16'-5"	14'-10"	29'-5"	26'-10"	25'-3"	23'-6"	19'-4"	33'-3"	30'-4"	28'-7"	26'-0"	19'-6"
14"	4500s 1.8	22'-9"	20'-7"	18'-9"	16'-9"	13'-11"	17'-10"	16'-3"	15'-4"	14'-3"	13'-0"	23'-10"	20'-7"	18'-9"	16'-9"	13'-11"	25'-7"	22'-4"	20'-2"	18'-0"	13'-11"
	5000s 1.8	23'-7"	21'-7"	20'-2"	18'-0"	13'-11"	18'-6"	16'-10"	15'-11"	14'-9"	13'-5"	25'-7"	22'-4"	20'-2"	18'-0"	13'-11"	27'-1"	23'-11"	21'-10"	19'-6"	15'-5"
	6000s 1.8	24'-6"	22'-5"	21'-2"	19'-6"	15'-5"	19'-2"	17'-6"	16'-6"	15'-4"	13'-11"	27'-1"	23'-11"	21'-10"	19'-6"	15'-5"	27'-9"	25'-2"	22'-11"	20'-6"	15'-5"
	6500s 1.8	25'-2"	23'-0"	21'-8"	20'-2"	15'-5"	19'-8"	17'-11"	16'-11"	15'-8"	14'-3"	27'-9"	25'-2"	22'-11"	20'-6"	15'-5"	29'-7"	27'-0"	25'-6"	21'-10"	16'-4"
	60s 2.0	26'-9"	24'-5"	23'-0"	21'-5"	16'-4"	20'-11"	19'-0"	17'-11"	16'-7"	15'-1"	29'-7"	27'-0"	25'-6"	21'-10"	16'-4"	33'-3"	30'-4"	28'-7"	26'-0"	19'-6"
	90s 2.0	30'-1"	27'-5"	25'-10"	24'-0"	19'-6"	23'-6"	21'-4"	20'-0"	18'-6"	16'-9"	33'-3"	30'-4"	28'-7"	26'-0"	19'-6"	36'-10"	33'-7"	31'-8"	26'-2"	19'-7"
16"	4500s 1.8	25'-2"	22'-0"	20'-1"	17'-11"	14'-1"	19'-9"	18'-0"	17'-0"	15'-10"	14'-1"	25'-5"	22'-0"	20'-1"	17'-11"	14'-1"	29'-6"	25'-6"	23'-4"	20'-10"	15'-9"
	6000s 1.8	27'-0"	24'-9"	23'-4"	20'-10"	15'-9"	21'-2"	19'-4"	18'-2"	16'-11"	15'-4"	29'-6"	25'-6"	23'-4"	20'-10"	15'-9"	30'-8"	26'-11"	24'-6"	21'-1"	15'-9"
	6500s 1.8	27'-9"	25'-4"	23'-11"	21'-1"	15'-9"	21'-9"	19'-9"	18'-8"	17'-4"	15'-8"	30'-8"	26'-11"	24'-6"	21'-1"	15'-9"	32'-8"	29'-10"	27'-4"	21'-10"	16'-4"
	60s 2.0	29'-7"	27'-0"	25'-6"	21'-10"	16'-4"	23'-2"	21'-1"	19'-10"	18'-5"	16'-4"	32'-8"	29'-10"	27'-4"	21'-10"	16'-4"	36'-10"	33'-7"	31'-8"	26'-2"	19'-7"
	90s 2.0	33'-4"	30'-4"	28'-7"	26'-2"	19'-7"	26'-0"	23'-7"	22'-2"	20'-6"	18'-7"	36'-10"	33'-7"	31'-8"	26'-2"	19'-7"					

- Span table is based on a residential floor load of 40 psf live load and 10 psf dead load (12 psf dead load for 90s 2.0 joists).
- Span values assume 23/32" minimum plywood/OSB rated sheathing is glued and nailed to joists for composite action (joists spaced at 32" o.c. require sheathing rated for such spacing - 7/8" plywood/OSB).
- Span values represent the most restrictive of simple or multiple span applications. Analyze multiple span joists with BC Calc® sizing software if the length of any span is less than half the length of an adjacent span.
- Span values are the maximum allowable clear distance between supports.

- Table values assume minimum bearing lengths without web stiffeners for joist depths of 16" inches and less.
- Floor tile will increase dead load and may require specific deflection limits, contact Boise Cascade EWP Engineering for further information.
- This table was designed to apply to a broad range of applications. It may be possible to exceed the limitations of this table by analyzing a specific application with the BC Calc® sizing software.

(Shaded values do not satisfy the requirements of the North Carolina State Building Code. Refer to the THREE STAR table when spans exceed 20 feet.)

One-Hour Fire Resistance Assembly

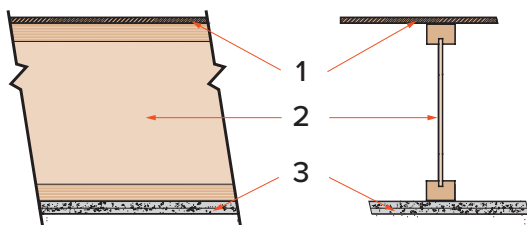

See the US version of the Boise Cascade Fire Design & Installation Guide for specific assembly information and other fire resistive options or contact your local Boise Cascade representative.

ICC-ES®/APA® ESR-1336

FIRE ASSEMBLY COMPONENTS

- Min. 23/32" thick tongue and groove sheathing (exterior glue), installed with long edge perpendicular to joist length, staggered one joist spacing with adjacent sheets, and glued to joists with construction adhesive.
- BCI® Joists at 24" o.c. or less.
- Two layers 5/8" Type X or two layers 1/2" Type C gypsum board, installed per Figures 2 or 3 of ICC-ES®/APA® ESR-1336.

SOUND ASSEMBLY COMPONENTS

When constructed with resilient channels

- Add carpet & pad to fire assembly;
- Add 3 1/2" glass fiber insulation to fire assembly;
- Add an additional layer of minimum 5/8" sheathing and 9 1/2" glass fiber insulation to fire assembly;

STC=54	IIC=68	or
STC=55	IIC=46	or
STC=61	IIC=50	

NOTE

The illustration below is showing several suggested applications for the Boise Cascade EWP products. It is not intended to show an actual house under construction.

NO MIDSPAN BRIDGING IS REQUIRED FOR BCI® JOISTS

FOR INSTALLATION STABILITY,
Temporary strut lines (1x4 min.) 8' on center max.
Fasten at each joist with 2-8d nails minimum.

Dimension lumber is not suitable for use as a rim board in BCI® floor systems.

F01 F02
BCI® rim joist.
See Floor Details below.

F07
Boise Cascade Rimboard.
See pages 6 and 25 of the Eastern Specifier Guide.

For load-bearing cantilever details, see pages 6-7

Additional floor framing details available with BCFramer® software

F06 F09
BCI® blocking or 2x4 "squash" block on each side required when supporting a load-bearing wall above.

When installing Boise Cascade EWP products with treated wood, use only connectors/fasteners that are approved for use with the corresponding wood treatment.

Versa-Lam® LVL header or an BCI® header.

1½" knockout holes at approximately 12" o.c. are pre-punched.

F58

F15

See page 7 for allowable hole sizes and location.

F27A
Versa-Lam® LVL beam.

Endwall blocking as required per governing building code.

BCI® Blocking is required when joists are cantilevered.

BCI® Joists — Floor Framing Details

END BEARING DETAILS

F07

Nail Boise Cascade® Rimboard to BCI® Joists with 8d nail into each flange.

Dimension lumber is not suitable for use as rim board with BCI® Joists.

F07A

Dimension lumber is not suitable for use as rimboard with BCI® Joists.

Blocking may be required perpendicular to wall, consult design professional of record and/or local building official.

F07B

2x_ ledger.

F02

BCI® rim joist.

Use of BCI® rimjoist requires 2x6 wall for minimum joist bearing.

F01

BCI® Joist blocking.

F27A

Top Flange or Face Mount Joist Hanger

Versa-Lam® LVL

F52

One 8d nail each side at bearing

1½" minimum bearing length

To limit splitting flange, start nails at least 1½" from end. Nails may need to be driven at an angle to limit splitting of bearing plate.

F08

Solid block all posts from above to bearing below.

F03

Boise Cascade® Rimboard

NOTE: BCI® floor joist must be designed to carry wall above when not stacked over wall below.

Blocking required underneath braced wall panels and shear walls, consult design professional of record.

INTERMEDIATE BEARING DETAILS

F06

For load bearing wall above (stacked over wall below).

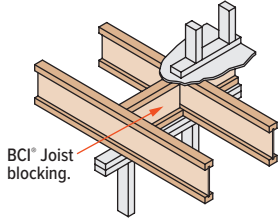

F05

Structural Panel reinforcement (when required).
BCI® Joist blocking required for cantilever.

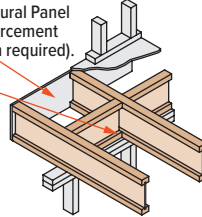

For load bearing cantilever, see pages 8 and 9. Uplift on backspan shall be considered in all cantilever designs.

F14

BCI® Joist Slope Cut Reinforcement
Detail below restores original allowable shear/reaction value to cut end of BCI® joist. BCI® Joist shall not be used as a collar or rafter tension tie.

2 x 6 min. rafter. Rafter shall be supported by ridge beam or other upper bearing support

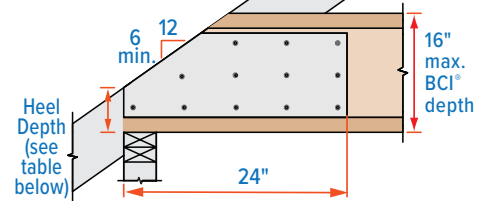

2x blocking required at bearing (not shown for clarity). 2 3/32" min. plywood/OSB rated sheathing as reinforcement. Install reinforcement with face grain horizontal. Install on both sides of the joist, tight to bottom flange. Leave minimum 1/4" gap between reinforcement and bottom of top flange. Apply construction adhesive to contact surfaces and fasten with 3 rows of min. 10d box nails at 6" o.c. Alternate nailing from each side and clinch.

F09

Blocking may be required at intermediate bearings for floor diaphragm per IRC in high seismic areas, consult local building official.

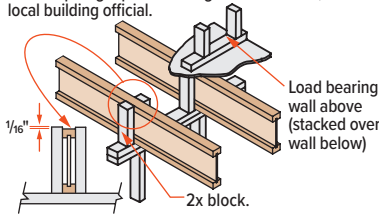

Size	Double Squash Block Vertical Load [lb/ft]			
	Joist Spacing [in]			
	12	16	19.2	24
2x4	4463	3347	2789	2231
2x6	7013	5259	4383	3506

- Squash blocks are to be in full contact with upper floor and lower wall plate.
- Capacities shown are for a double squash blocks at each joist, SPF or better.

F10

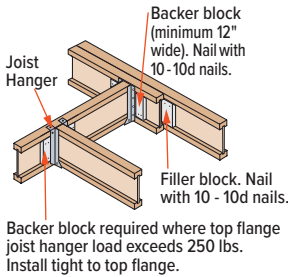

Backer block required where top flange joist hanger load exceeds 250 lbs. Install tight to top flange.

F58

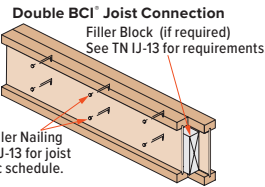

- Filler block not required when all loads are top loaded and evenly applied to each ply (except BCI® 90 and AJS® 25, 30). Side loads and/or uneven top loads require filler block.
- See Boise Cascade Technical Note UJ-13 for further information.
- Fasten floor sheathing to each ply per diaphragm nailing schedule.

End Wall Bearing	Minimum Heel Depth					
	Roof Pitch					
	6/12	7/12	8/12	9/12	10/12	12/12
2 x 4	4 3/8"	4 5/16"	4 1/4"	4 1/4"	4 1/4"	4 1/4"
2 x 6	3 3/8"	3 3/16"	2 5/16"	2 3/4"	2 1/16"	2 1/4"

LATERAL SUPPORT

- BCI® Joists shall be laterally supported at the ends with hangers, rimboard, BCI® rim joist or blocking panels. BCI® blocking panels or rimboard are required at cantilever supports.
- Blocking may be required at intermediate bearings for floor diaphragm per IRC® in high seismic areas, consult local building official.

MINIMUM BEARING LENGTH FOR BCI® JOISTS

- Minimum end bearing: 1 1/2" for all BCI® Joists. 3 1/2" is required at cantilever and intermediate supports.
- Longer bearing lengths allow higher reaction values. Refer to the building code evaluation report or the BC Calc® software.

NAILING REQUIREMENTS

- BCI® rim joist, rim board or closure panel to BCI® joist:
 - Rims or closure panel 1 5/16 inches thick and less: 2-8d nails, one each in the top and bottom flange.
 - BCI® 4500s/5000s rim joist: 2-10d box nails, one each in the top and bottom flange.
 - BCI® 6000s/60s rim joist: 2-16d box nails, one each in the top and bottom flange.
 - BCI® 6500s/90s rim joist: Toe-nail top flange to rim joist with 2-10d box nails, one each side of flange.
- BCI® rim joist, rim board or BCI® blocking panel to support:
 - Min. 8d nails @ 6" o.c. per IRC®.
 - Connection per design professional of record's specification for shear transfer.
- BCI® joist to support:
 - 2-8d nails, one on each side of the web, placed 1 1/2 inches minimum from the end of the BCI® Joist to limit splitting.

- Sheathing to BCI® joist:
 - Prescriptive residential floor sheathing nailing requires 8d common nails @ 6" o.c. on edges and @ 12" o.c. in the field (IRC® Table R602.3(1)).
 - See closest allowable nail spacing limits on page 24 for floor diaphragm nailing specified at closer spacing than IRC®.
 - Maximum bracing spacing for full lateral stability: 18" for BCI® 4500s & 5000s, 24" for larger BCI® joist series.
 - 14 gauge staples may be substituted for 8d nails if the staples penetrate at least 1 inch into the joist.
 - Wood screws may be acceptable, contact local building official and/or Boise Cascade EWP Engineering for further information.

BACKER AND FILLER BLOCK DIMENSIONS

Series	Backer Block Thickness	Filler Block Thickness
4500s 1.8	5/8" or 3/4" wood panels	Two 5/8" wood panels or 2 x _
5000s 1.8	3/4" or 7/8" wood panels	Two 3/4" wood panels or 2 x _
6000s 1.8	1 1/8" or two 1/2" wood panels	2 x _ + 7/16" or 1/2" wood panel
6500s 1.8	1 1/8" or two 5/8" wood panels	2 x _ + 5/8" or 3/4" wood panel
60s 2.0	1 1/8" or two 1/2" wood panels	2 x _ + 7/16" or 1/2" wood panel
90s 2.0	2 x _ lumber	Double 2 x _ lumber

- Cut backer and filler blocks to a maximum depth equal to the web depth minus 1/4" to avoid a forced fit.

WEB STIFFENER REQUIREMENTS

- See *Web Stiffener Requirements* on page 7.

PROTECT BCI® JOISTS FROM THE WEATHER

- BCI® Joists are intended only for applications that provide permanent protection from the weather. Bundles of product should be covered and stored off of the ground on stickers.

BCI® RIM JOISTS AND BLOCKING

Depth [in]	Series	Vertical Load Capacity (plf)	
		No W.S. ⁽¹⁾	W.S. ⁽²⁾
9 1/2"	4500s 1.8, 5000s 1.8, 6000s 1.8, 6500s 1.8	2300	N/A
	60s 2.0, 90s 2.0	2500	N/A
11 7/8"	4500s 1.8, 5000s 1.8, 6000s 1.8, 6500s 1.8	2150	N/A
	60s 2.0, 90s 2.0	2400	N/A
14"	4500s 1.8, 5000s 1.8, 6000s 1.8, 6500s 1.8	2000	N/A
	60s 2.0, 90s 2.0	2400	N/A
16"	4500s 1.8, 6000s 1.8, 6500s 1.8	1900	2500
	60s 2.0, 90s 2.0	2300	2700

- (1) No web stiffeners required.
 (2) Web stiffeners required at each end of blocking, values not applicable for rim joists.
 N/A: Not applicable

Closest Allowable Nail Spacing

BCI® Joists		All BCI® Joists			
		Nailing Perpendicular to Glue Line (Wide Face)		Nailing Parallel to Glue Line (Narrow Face)	
		O.C. Spacing [inches]	End of Joist [inches]	O.C. Spacing [inches]	End of Joist [inches]
Nail Size					
8d Box (0.113"ø x 2.5")		2	1 1/2	4	1 1/2
8d Common (0.131"ø x 2.5")		2	1 1/2	4	3
10d & 12d Box (0.128"ø x 3", 3.25")		2	1 1/2	4	3
16d Box (0.135"ø x 3.5")		2	1 1/2	4	3
10d & 12d Common & 16d Sinker (0.148"ø x 3", 3.25")		3	2	6	4
16d Common (0.162"ø x 3.5")		3	2	6	4

- If more than one row of nails is used, the rows must be offset at least 1/2 inch.
- Simpson Strong-Tie A35 connectors may be attached to the side of BCI® 60s and 90s joist flanges only. Use nails as specified by Simpson Strong-Tie; do not attach connectors on both sides of a flange at the same location.

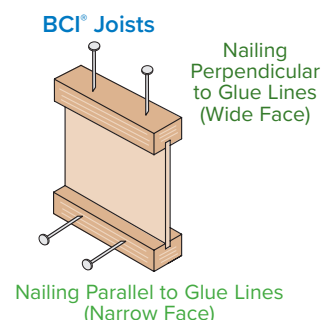

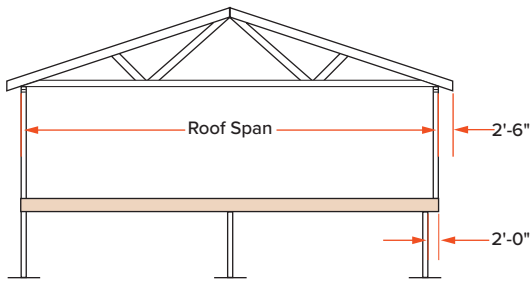

- The tables and details on pages 8 and 9 indicate the type of reinforcements, if any, that are required for load-bearing cantilevers up to a maximum length of 2'-0". Cantilevers longer than 2'-0" cannot be reinforced. **However, longer cantilevers with lower loads may be allowable without reinforcement. Analyze specific applications with the BC Calc® software.**

PLYWOOD / OSB REINFORCEMENT (If Required per Table on page 8 or BC Calc® Analysis)

- 2³/₃₂" Min. x 48" long plywood / OSB rated sheathing must match the full depth of the BCI® Joist. Nail to the BCI® Joist with 8d nails at 6" o.c. and nail with 4-8d nails into backer block. When reinforcing both sides, stagger nails to limit splitting. Install with horizontal face grain.
- The tables on page 8 assume a wall weight of 100 plf, in addition to the roof loading shown. Applications with loading that exceeds the loads shown shall be analyzed with BC Calc® software.
- These requirements assume a 100 PLF wall load. Additional support may be required for other loadings, see BC Calc® software.

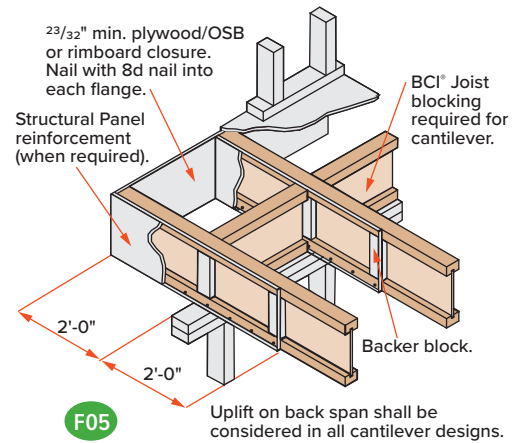

Non-Load Bearing Wall Cantilever Details

BCI® Joists are intended only for applications that provide permanent protection from the weather. Impervious moisture barrier systems shall be detailed and installed in details F15A and F15B in accordance with 2018 IBC® Sections 107.2.5 and 110.3.6.

Fasten the 2x8 minimum to the BCI® Joist by nailing through the backer block and joist web with 2 rows of 10d nails at 6" on-center. Clinch all nails. For BCI® 90 joists, nail each side with 2 rows (4 rows total) of 16d nails at 6" on-center.

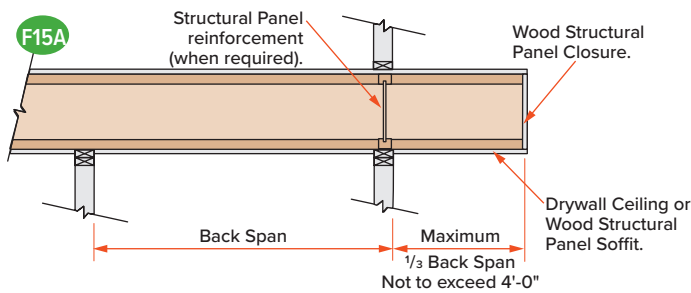

- Analyze BCI® Joist cantilever condition with BC Calc® software.

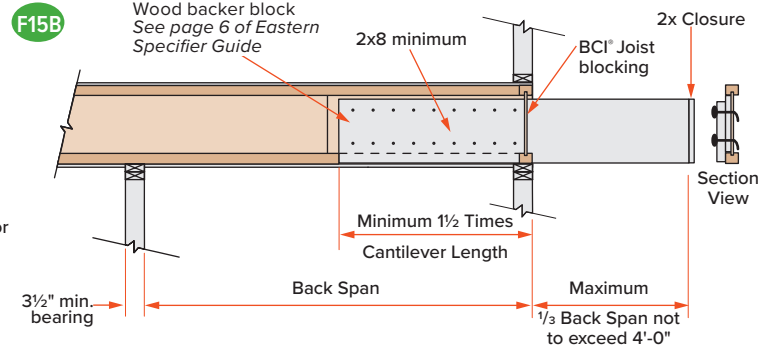

- Loading shall not exceed 60 psf live load and 10 psf dead load. At least three joist members shall be present and spaced at 24" o.c. or less.
- Lumber joist shall be No. 2 Dense Southern Pine, No.1/No.2 SPF, No.2 Hem-fir, or No.2 Douglas fir, or higher grade.
- Provide positive drainage, durable materials, and venting as required in 2018 IBC Sections 2304.12.2.5 and 2304.12.2.6. Lumber joist shall be sloped.

Web Stiffener Requirements

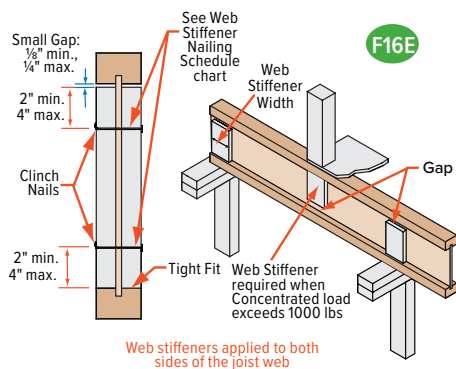

NOTES

- Web stiffeners are optional except as noted below.
- Web stiffeners are always required in hangers that do not extend up to support the top flange of the BCI® Joist. Web stiffeners may be required with certain sloped or skewed hangers or to achieve uplift values. Refer to the hanger manufacturer's installation requirements.
- Web stiffeners are always required in certain roof applications. See Roof Framing Details on page 10-11.
- Web stiffeners are always required under concentrated loads that exceed 1000 pounds. Install the web stiffeners snug to the top flange in this situation. Follow the nailing schedule for intermediate bearings.
- Web stiffeners may be cut from structural rated wood panels, engineered rimboard or 2x lumber (BCI® 90s only).
- For Structural Capacity: Web stiffeners needed to increase the BCI® Joist's reaction capacity at a specific bearing location.
- Lateral Restraint in Hanger: Web stiffeners required when hanger does not laterally support the top flange (e.g., adjustable height hangers). Web stiffeners may be of multiple thickness (e.g., BCI® 6500s, double 1/2" panel OK).
- Web stiffeners may be used to increase allowable reaction values. See BCI® Design Properties on page 24 of the specifier guide or the BC Calc® software.

Web Stiffener Specifications			
BCI® Joist Series	For Structural Capacity (Min. Thick)	Lateral Restraint in Hanger	Minimum Width
4500s 1.8	5/8"	5/8"	2 ⁵ / ₁₆ "
5000s 1.8	5/8"	3/4"	2 ⁵ / ₁₆ "
6000s 1.8	3/4"	7/8"	2 ⁵ / ₁₆ "
6500s 1.8	3/4"	1" or 1 ¹ / ₈ "	2 ⁵ / ₁₆ "
60s 2.0	3/4"	7/8"	2 ⁵ / ₁₆ "
90s 2.0	2x4 lumber (vertical)		

Web Stiffener Nailing Schedule

BCI® Joist Series	Joist Depth	Bearing Location	
		End	Intermediate
4500s 1.8	9 ¹ / ₂ "	2-8d	2-8d
	11 ⁷ / ₈ "	2-8d	3-8d
	14"	2-8d	5-8d
	16"	2-8d	6-8d
5000s 1.8	9 ¹ / ₂ "	2-8d	2-8d
	11 ⁷ / ₈ "	2-8d	3-8d
	14"	2-8d	5-8d
6000s 1.8	9 ¹ / ₂ "	2-8d	2-8d
	11 ⁷ / ₈ "	2-8d	3-8d
	14"	2-8d	5-8d
6500s 1.8	9 ¹ / ₂ "	2-8d	2-8d
	11 ⁷ / ₈ "	2-8d	3-8d
	14"	2-8d	5-8d
60s 2.0	11 ⁷ / ₈ "	2-8d	3-8d
	14"	2-8d	5-8d
	16"	2-8d	6-8d
90s 2.0	11 ⁷ / ₈ "	3-16d	3-16d
	14"	5-16d	5-16d
	16"	6-16d	6-16d

BCI® Joists are manufactured with 1½" round perforated knockouts in the web at approximately 12" on center

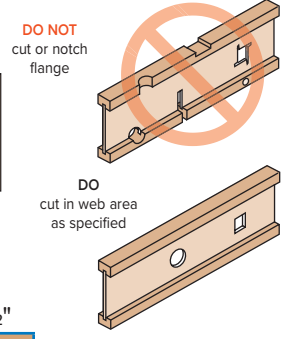
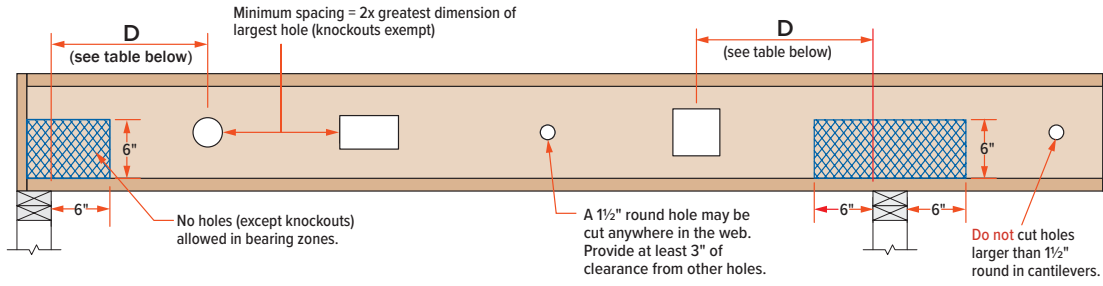

Minimum distance from support, listed in table below, is required for all holes greater than 1½"

MINIMUM DISTANCE (D) FROM ANY SUPPORT TO THE CENTERLINE OF THE HOLE																
Round Hole Diameter [in]		2	3	4	5	6	6½	7	8	8¾	9	10	11	12	13	
Rectangular Hole Side [in]		-	-	-	3	5	6	7	-	-	-	-	-	-	-	
Any 9½" Joist	Span [ft]	8	1'-0"	1'-1"	1'-5"	2'-1"	2'-9"	3'-1"	3'-5"							
		12	1'-0"	1'-2"	2'-2"	3'-2"	4'-2"	4'-8"	5'-2"							
		16	1'-0"	1'-7"	2'-11"	4'-3"	5'-7"	6'-3"	6'-11"							
Round Hole Diameter [in]		2	3	4	5	6	6½	7	8	8¾	9	10	11	12	13	
Rectangular Hole Side [in]		-	-	-	2	3	4	5	7	8	-	-	-	-	-	
Any 11¾" Joist	Span [ft]	8	1'-0"	1'-1"	1'-5"	1'-10"	2'-4"	2'-7"	2'-10"	3'-4"	3'-9"					
		12	1'-0"	1'-4"	2'-1"	2'-10"	3'-7"	3'-11"	4'-3"	5'-0"	5'-8"					
		16	1'-0"	1'-10"	2'-10"	3'-9"	4'-9"	5'-3"	5'-9"	6'-9"	7'-7"					
		20	1'-1"	2'-3"	3'-6"	4'-9"	5'-11"	6'-7"	7'-2"	8'-5"	9'-6"					
Round Hole Diameter [in]		2	3	4	5	6	6½	7	8	8¾	9	10	11	12	13	
Rectangular Hole Side [in]		-	-	-	-	2	3	3	5	6	6	8	9	-	-	
Any 14" Joist	Span [ft]	8	1'-0"	1'-1"	1'-2"	1'-3"	1'-8"	1'-10"	2'-1"	2'-6"	2'-10"	2'-11"	3'-4"	3'-8"		
		12	1'-0"	1'-1"	1'-3"	1'-10"	2'-6"	2'-10"	3'-1"	3'-9"	4'-3"	4'-4"	5'-0"	5'-7"		
		16	1'-0"	1'-1"	1'-8"	2'-6"	3'-4"	3'-9"	4'-2"	5'-0"	5'-8"	5'-10"	6'-8"	7'-5"		
		20	1'-0"	1'-1"	2'-1"	3'-2"	4'-2"	4'-8"	5'-2"	6'-3"	7'-2"	7'-3"	8'-4"	9'-4"		
		24	1'-0"	1'-4"	2'-6"	3'-9"	5'-0"	5'-8"	6'-3"	7'-6"	8'-7"	8'-9"	10'-0"	11'-2"		
Round Hole Diameter [in]		2	3	4	5	6	6½	7	8	8¾	9	10	11	12	13	
Rectangular Hole Side [in]		-	-	-	-	-	-	2	3	5	5	6	8	9	10	
Any 16" Joist	Span [ft]	8	1'-0"	1'-1"	1'-2"	1'-2"	1'-3"	1'-3"	1'-3"	1'-7"	1'-11"	2'-0"	2'-5"	2'-9"	3'-2"	3'-7"
		12	1'-0"	1'-1"	1'-2"	1'-2"	1'-3"	1'-6"	1'-10"	2'-5"	2'-11"	3'-0"	3'-7"	4'-2"	4'-9"	5'-4"
		16	1'-0"	1'-1"	1'-2"	1'-2"	1'-8"	2'-1"	2'-6"	3'-3"	3'-11"	4'-0"	4'-10"	5'-7"	6'-4"	7'-2"
		20	1'-0"	1'-1"	1'-2"	1'-2"	2'-1"	2'-7"	3'-1"	4'-1"	4'-11"	5'-1"	6'-0"	7'-0"	8'-0"	8'-11"
		24	1'-0"	1'-1"	1'-2"	1'-4"	2'-6"	3'-1"	3'-9"	4'-11"	5'-11"	6'-1"	7'-3"	8'-5"	9'-7"	10'-9"

- Select a table row based on joist depth and the actual joist span rounded up to the nearest table span. Scan across the row to the column headed by the appropriate round hole diameter or rectangular hole side. Use the longest side of a rectangular hole. The table value is the closest that the centerline of the hole may be to the centerline of the nearest support.
- The entire web may be cut out. **DO NOT** cut the flanges. Holes apply to either single or multiple joists in repetitive member conditions.
- For multiple holes, the amount of uncut web between holes must equal at least twice the diameter (or longest side) of the largest hole.
- 1½" round knockouts in the web may be removed by using a short piece of metal pipe and hammer.
- Holes may be positioned vertically in the web, provided they don't extend into either flange.
- This table was designed to apply to design conditions covered by uniform load PLF tables only, shown elsewhere in this publication. Use BC Calc® software to check other hole sizes or holes under other design conditions, including joists supporting concentrated loads. It may be possible to exceed the limitations of this table by analyzing a specific application with the BC Calc® software.

Large Rectangular Holes in BCI® Joists

Hole size table based on maximum uniform load of 40 psf live load and 10 psf dead load, at maximum spacing of 24" on-center.

Single Span Joist

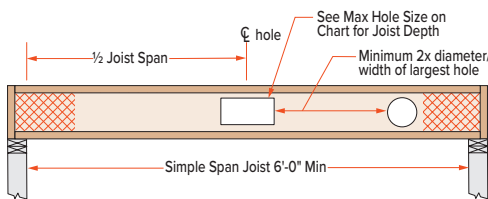

Joist Depth	Maximum Hole Size	
	Simple Span	Multiple Span
9½"	6" x 14"	6" x 12"
11¾"	7" x 16" 8" x 15"	8" x 12"
14"	9" x 16" 10" x 15"	8" x 15"
16"	9" x 18" 11" x 16"	10" x 14"

Multiple Span Joist

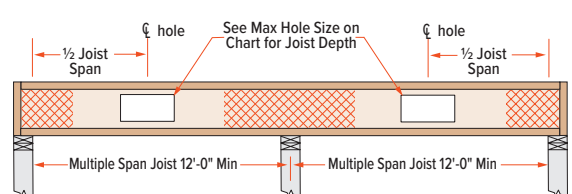

Larger holes may be possible for either Single or Multiple span joists; use BC Calc® sizing software for specific analysis.

Notes:

Additional holes may be cut in the web provided they meet the specifications as shown in the hole distance chart shown above or as allowed using BC Calc® sizing software.

Notes

- Square and rectangular holes are not permitted.
- Round holes may be drilled or cut with a hole saw anywhere within the shaded area of the beam.
- The horizontal distance between adjacent holes must be at least two times the size of the larger hole.
- Do not drill more than three access holes in any four foot long section of beam.
- The maximum round hole diameter permitted is:

Beam Depth	Max. Hole Diameter
5½"	¾"
7¼"	1"
9¼" and greater	2"

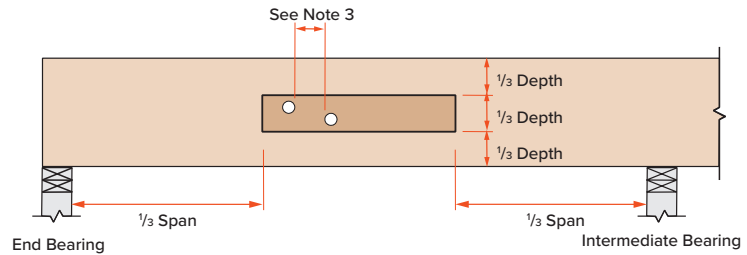

- These limitations apply to holes drilled for plumbing or wiring access only. The size and location of holes drilled for fasteners are governed by the provisions of the *National Design Specification® for Wood Construction*.
- Beams deflect under load. Size holes to provide clearance where required.
- This hole chart is valid for beams supporting uniform load only. For beams supporting concentrated loads or for beams with larger holes, use BC Calc® sizing software (www.BCCalc.com) or contact Boise Cascade EWP Engineering.

Versa-Lam® LVL Products Nail Size		Nailing Parallel to Glue Lines (Narrow Face) ⁽¹⁾						Nailing Perpendicular to Glue Lines (Wide Face)	
		Versa-Lam® LVL 1½"		Versa-Lam® LVL 1¾"		Versa-Lam® LVL 3½" & Wider		All Products	
		O.C. [in]	End [in]	O.C. [in]	End [in]	O.C. [in]	End [in]	O.C. [in]	End [in]
8d Box (0.113"ø x 2.5")	3	1½	2	1	2	½	2	½	
8d Common (0.131"ø x 2.5")	3	2	3	2	2	1	2	1	
10d & 12d Box (0.128"ø x 3", 3.25")	3	2	3	2	2	1	2	1	
16d Box (0.135"ø x 3.5")	3	2	3	2	2	1	2	1	
10d & 12d Common & 16d Sinkers (0.148"ø x 3", 3.25")	4	3	4	3	2	2	2	2	
16d Common (0.162"ø x 3.5")	6	4	6	3	2	2	2	2	

- Offset and stagger nail rows from floor sheathing and wall sole plate.
- Simpson Strong-Tie A35 and LPT4 connectors may be attached to the side Versa-Lam® LVL/ Versa-Rim® LVL. Use nails as specified by Simpson Strong-Tie.

Versa-Lam® LVL & Versa-Rim® Products

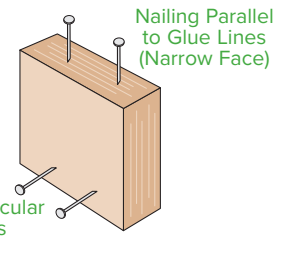

Nailing Notes

- For 1¾" thickness and greater, 2 rows of nails (such as for a metal strap) are allowed (use ½" minimum offset between rows and stagger nails).

Boise Cascade Rimboard Properties

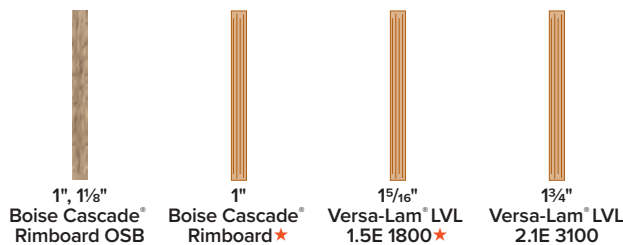

★ Product may not be available. Check with supplier or Boise Cascade representative for availability.

Product	Vertical Load Capacity		Maximum Floor Diaphragm Lateral Capacity [lb/ft]	Allowable Design Values			
	Uniform [plf]	Point [lb]		Flexural Stress [lb/in ²]	Modulus of Elasticity [lb/in ²]	Horizontal Shear [lb/in ²]	Compression Perpendicular to Grain [lb/in ²]
1" BC RIM BOARD® ⁽²⁾ 1" BC RIM BOARD® OSB ⁽²⁾	3300	3500	180	Limited span capabilities, see note 2			
1½" BC RIM BOARD® OSB ⁽²⁾	4400	3500	180	Limited span capabilities, see note 2			
1½" VERSA-LAM® 1.4 1800 ⁽¹⁾	6000	4450	Permitted per building code for all nominal 2" thick framing floor diaphragms	1800	1,400,000	225	525
1¾" VERSA-LAM® 2.0 3100 ⁽¹⁾	5700	4300	Permitted per building code for all nominal 2" thick framing floor diaphragms	3100	2,000,000	285	750

Closest Allowable Nail Spacing - Narrow Face [in]	Product			
	1" Boise Cascade® Rimboard ⁽²⁾ 1" Boise Cascade® Rimboard OSB ⁽²⁾	1½" Boise Cascade® Rimboard OSB ⁽²⁾	1½" Versa-Lam® LVL 1.4 1800 ⁽¹⁾	1¾" Versa-Lam® LVL 2.1 3100 ⁽¹⁾
8d Box (0.113"ø x 2.5")	3	3	3	3
8d Common (0.131"ø x 2.5")	3	3	3	3
10d & 12d Box (0.128"ø x 3", 3.25")	See publication in note 2 for further nailing information.			
16d Box (0.135"ø x 3.5")				
10d & 12d Common & 16d Sinkers (0.148"ø x 3", 3.25")				
16d Common (0.162"ø x 3.5")				

Notes

- See ICC-ES®/APA® ESR-1040 for further information.
- See *Performance Rated Rim Boards, APA® Form No. W345N* for further product information.

BCI® Joists, Versa-Lam® LVL, and ALLJOIST® must be stored, installed and used in accordance with the Boise Cascade EWP Installation Guide, building codes, and to the extent not inconsistent with the Boise Cascade EWP Installation Guide, usual and customary building practices and standards. Versa-Lam® LVL, ALLJOIST® and BCI® Joists must be wrapped, covered, and stored off of the ground on stickers at all times prior to installation. Versa-Lam® LVL, ALLJOIST®

and BCI® Joists are intended only for applications that assure no exposure to weather or the elements and an environment that is free from moisture from any source, or any pest, organism or substance which degrades or damages wood or glue bonds. Failure to correctly store, use or install Versa-Lam® LVL, ALLJOIST® and BCI® Joist in accordance with the Boise Cascade EWP Installation Guide will void the limited warranty.

BCI® Rafter

Additional roof framing details available with BC Framer® software

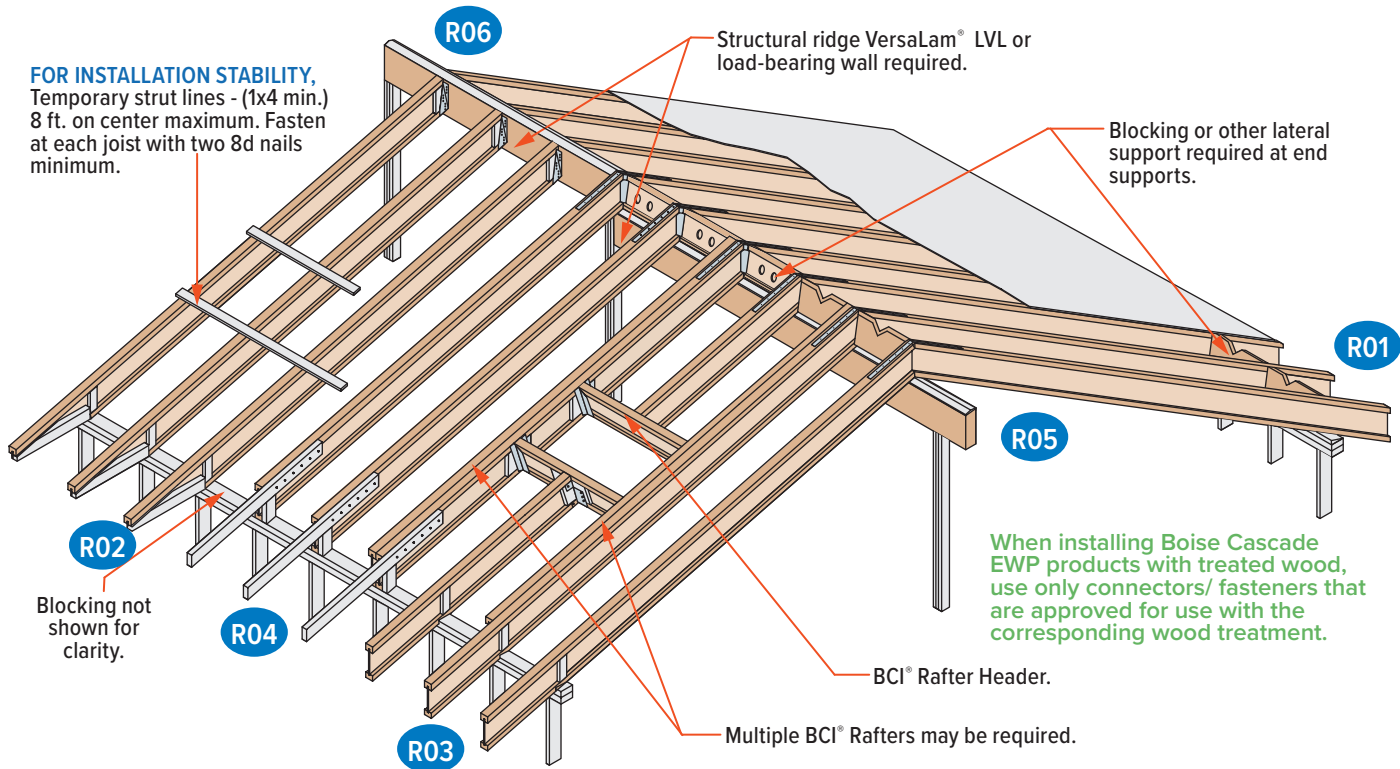

SAFETY WARNING

DO NOT ALLOW WORKERS ON BCI® JOISTS UNTIL ALL HANGERS, BCI® RIM JOISTS, RIM BOARDS, BCI® BLOCKING PANELS, X-BRACING AND TEMPORARY 1x4 STRUT LINES ARE INSTALLED AS SPECIFIED BELOW.

SERIOUS ACCIDENTS CAN RESULT FROM INSUFFICIENT ATTENTION TO PROPER BRACING DURING CONSTRUCTION. ACCIDENTS CAN BE AVOIDED UNDER NORMAL CONDITIONS BY FOLLOWING THESE GUIDELINES:

- Build a braced end wall at the end of the bay, or permanently install the first eight feet of BCI® Joists and the first course of sheathing. As an alternate, temporary sheathing may be nailed to the first four feet of BCI® Joists at the end of the bay.
- All hangers, BCI® rim joists, rim boards, BCI® blocking panels, and x-bracing must be completely installed and properly nailed as each BCI® Joist is set.
- Install temporary 1x4 strut lines at no more than eight feet on center as additional BCI® Joists are set. Nail the strut lines to the sheathed area, or braced end wall, and to each BCI® Joist with two 8d nails.
- The ends of cantilevers must be temporarily secured by strut lines on both the top and bottom flanges.
- Straighten the BCI® Joists to within 1/2 inch of true alignment before attaching strut lines and sheathing.
- Remove the temporary strut lines only as required to install the permanent sheathing.
- Failure to install temporary bracing may result in sideways buckling or roll-over under light construction loads.

BCI® Ceiling Joist with Bevel End Cut (For Limited-Access Attics Only)

BCI® Joist shall not be used as collar/tension tie. Roof rafter shall be supported by ridge beam or other upper bearing support.

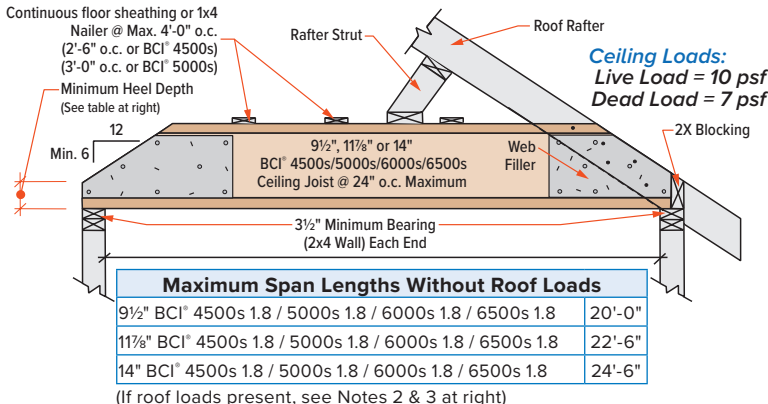

Minimum Heel Depths	Joist Depth	End Wall	
		2 x 4	2 x 6
9 1/2"	9 1/2"	2 1/2"	1 1/2"
11 7/8"	11 7/8"	3 1/2"	2 1/2"
14"	14"	4 1/2"	3 1/2"

Notes:

- 1) Detail is to be used only for ceiling joists with no access to attic space.
- 2) Ceiling joist must be designed to carry all roof load transferred through rafter struts as shown.
- 3) BCI® ceiling joist end reaction may not exceed 550 pounds.
- 4) Minimum roof slope is 6/12.
- 5) Nail roof rafter to BCI® top flange with 1-10d (3" long) box or larger nail.
- 6) 1x4 nailers must be continuous and nailed to a braced end wall.
- 7) Install a web filler on each side of BCI® Joist at beveled ends. Nail roof rafter to BCI® Joist per building code requirements for ceiling joist to roof rafter connection.

Additional roof framing details available with BC Framer® software

R01

2x beveled plate for slope greater than 1/4/12.

Simpson VPA or USP TMP connectors or equal can be used in lieu of beveled plate for slopes from 3/12 to 12/12.

R02

Rimboard / Versa-Lam® LVL blocking. Ventilation "V" cut: 1/3 of length, 1/2 of depth

2x4 blocking for soffit support. 2'-6" max.

Flange of BCI® Joists may be birdsmouth cut only at the low end of the joist. Birdsmouth cut BCI® Joist flange must bear fully on plate, web stiffener required each side. Bottom flange shall be fully supported.

R03

Rimboard / Versa-Lam® LVL blocking. Ventilation "V" cut: 1/3 of length, 1/2 of depth

Tight fit for lateral stability. 2'-6" max.

Flange of BCI® Joists may be birdsmouth cut only at the low end of the joist. Birdsmouth cut BCI® Joist flange must bear fully on plate, web stiffener required each side.

R04

10d nails at 6" o.c. 2x4 one side for 135 PLF max. 2x6 one side for 240 PLF max.

Backer block. Thickness per corresponding BCI® series. 2x block. BCI® blocking. Holes cut for ventilation. 4'-0" horiz.

R05

Simpson or USP LSTA24 strap, nailing per governing building code.

Versa-Lam® LVL support beam. BCI® blocking. Holes cut for ventilation. Double-beveled wood plate.

Blocking on both sides of ridge may be required for shear transfer per design professional of record.

R06

Simpson or USP LSTA24 strap where slope exceeds 7/12 (straps may be required for lower slopes in high-wind areas). Nailing per governing building code.

Versa-Lam® LVL support beam. Beveled web stiffener on each side. Simpson LSSU or USP TMU hanger.

R07

Backer block (minimum 12" wide). Nail with 10 - 10d nails. Joist Hanger. Filler block. Nail with 10 - 10d nails.

Backer block required where top flange joist hanger load exceeds 250 lbs. Install tight to top flange.

R11

Double joist may be required when L exceeds rafter spac. Blocking as required. Nail outrigger through BCI® web. 2" x _ outrigger notched around BCI® top flange. Outrigger spacing no greater than L (2'-0" max.).

DN05

DO NOT bevel-cut joist beyond inside face of wall, except for specific conditions in details shown on pages 6 and 13 of the Specifier Guide.

NOTES TO ROOF FRAMING DETAILS

LATERAL SUPPORT

- BCI® Joists must be laterally supported at end supports (including supports adjacent to overhangs) with hangers, rimboard, or blocking (Versa-Lam® LVL, Boise Cascade® Rimboard or BCI® Joist). Metal cross bracing or other x-bracing provides adequate lateral support for BCI® Joists, consult governing building code for roof diaphragm connection provisions.

MINIMUM BEARING LENGTH FOR BCI® JOISTS

- Minimum end bearing: 1½" for all BCI® Joists. 3½" is required at cantilever and intermediate supports.
- Longer bearing lengths allow higher reaction values. Refer to the building code evaluation report or the BC Calc® software.

NAILING REQUIREMENTS

- BCI® rim joist, rim board or closure panel to BCI® joist:
 - Rims or closure panel 1¼ inches thick and less: 2-8d nails, one each in the top and bottom flange.
 - BCI® 4500s/5000s rim joist: 2-10d box nails, one each in the top and bottom flange.
 - BCI® 6000s/60s rim joist: 2-16d box nails, one each in the top and bottom flange.
 - BCI® 6500s/90s rim joist: Toe-nail top flange to rim joist with 2-10d box nails, one each side of flange.
- BCI® rim joist, rim board or BCI® blocking panel to support:
 - Min. 8d nails @ 6" o.c. per IRC®.
 - Connection per design professional of record's specification for shear transfer.
- BCI® joist to support:
 - 2-8d nails, one on each side of the web, placed 1½ inches minimum from the end of the BCI® Joist to limit splitting.

WEB STIFFENER REQUIREMENTS

- Sheathing to BCI® joist:
 - Prescriptive residential floor sheathing nailing requires 8d common nails @ 6" o.c. on edges and @ 12" o.c. in the field (IRC® Table R602.3(1)).
 - See closest allowable nail spacing limits on page 5 for floor diaphragm nailing specified at closer spacing than IRC®.
 - Maximum nail spacing for minimum lateral stability: 18" for BCI® 4500s and 5000s, 24" for larger BCI® joist series.
 - 14 gauge staples may be substituted for 8d nails if the staples penetrate at least 1 inch into the joist.
 - Wood screws may be acceptable, contact local building official and/or Boise Cascade EWP Engineering for further information.

BACKER AND FILLER BLOCK DIMENSIONS

Series	Backer Block Thickness	Filler Block Thickness
4500s 1.8	5/8" or 3/4" wood panels	Two 5/8" wood panels or 2 x _
5000s 1.8	3/4" or 7/8" wood panels	Two 3/4" wood panels or 2 x _
6000s 1.8	1 1/8" or two 1/2" wood panels	2 x _ + 7/16" or 1/2" wood panel
6500s 1.8	1 1/8" or two 5/8" wood panels	2 x _ + 5/8" or 3/4" wood panel
60s 2.0	1 1/8" or two 1/2" wood panels	2 x _ + 7/16" or 1/2" wood panel
90s 2.0	2 x _ lumber	Double 2 x _ lumber

- Cut backer and filler blocks to a maximum depth equal to the web depth minus ¼" to avoid a forced fit.

PROTECT BCI® JOISTS FROM THE WEATHER

- See *Web Stiffener Requirements* on page 9.

MAXIMUM SLOPE

- BCI® Joists are intended only for applications that provide permanent protection from the weather. Bundles of BCI® Joists should be covered and stored off of the ground on stickers.

VENTILATION

- Unless otherwise noted, all roof details are valid for slopes of 12 in 12 or less.

BIRDSMOUTH CUTS

- The 1½ inch, pre-stamped knock-out holes spaced at 12 inches on center along the BCI® Joist may all be knocked out and used for cross ventilation. Deeper joists that what is structurally needed may be advantageous in ventilation design. Consult local building official and/or ventilation specialist for specific ventilation requirements.

BIRDSMOUTH CUTS

- BCI® Joists may be birdsmouth cut only at the low end support. BCI® Joists with birdsmouth cuts may cantilever up to 2'-6" past the low end support. The bottom flange must sit fully on the support and may not overhang the inside face of the support. High end supports and intermediate supports may not be birdsmouth cut.

BEARING AT CONCRETE/MASONRY WALLS

Provide moisture barrier and lateral restraint at bearing.

1/2" air space required between concrete and wood.

B01

BEARING FOR DOOR OR WINDOW HEADER

Strap per code if top plate is not continuous over header.

Trimmers.

B02

BEAM TO BEAM CONNECTOR

Verify hanger capacity with hanger manufacturer.

B03

BEARING AT COLUMN

Versa-Lam® LVL column.

Column connector per design professional of record.

B04

SLOPE SEAT CUT

Sloped seat cut. Not to exceed inside face of bearing.

Blocking not shown for clarity.

B06

BEVEL CUT

DO NOT bevel cut Versa-Lam® LVL beyond inside face of wall without approval from Boise Cascade EWP Engineering or BC Calc® software analysis.

B07

BEAM TO CONCRETE/MASONRY WALLS

Wood top plate must be flush with inside of wall.

Hanger.

Moisture barrier between concrete and wood.

B08

BEARING FRAMING INTO WALL

Strap per code if top plate is not continuous.

B09

INSTALLATION NOTES

- Minimum of 1/2" air space between beam and wall pocket or adequate barrier must be provided between beam and concrete/masonry.
- Adequate bearing shall be provided. If not shown on plans, please refer to load tables on your region's specifier guide, pages 28-30.

- Versa-Lam® LVL beams are intended for interior applications only and should be kept as dry as possible during construction.
- Continuous lateral support of top of beam shall be provided (side or top bearing framing).

Multiple Member Connectors

Side-Loaded Applications								
Number of Members	Maximum Uniform Side Load [plf]							
	Nailed ⁽³⁾		1/2" Dia. Through Bolt ⁽¹⁾			5/8" Dia. Through Bolt ⁽¹⁾		
	2 rows 16d Sinks @ 12" o.c.	3 rows 16d Sinks @ 12" o.c.	2 rows @ 24" o.c. staggered	2 rows @ 12" o.c. staggered	2 rows @ 6" o.c. staggered	2 rows @ 24" o.c. staggered	2 rows @ 12" o.c. staggered	2 rows @ 6" o.c. staggered
1 3/4" Versa-Lam® LVL (Depths of 18" and less)								
2	470	705	505	1010	2020	560	1120	2245
3 ⁽²⁾	350	525	375	755	1515	420	840	1685
4 ⁽³⁾	use bolt schedule		335	670	1345	370	745	1495
3 1/2" Versa-Lam® LVL								
2 ⁽³⁾	use bolt schedule		855	1715	N/A	1125	2250	N/A
1 3/4" Versa-Lam® LVL (Depths of 24" and less)								
Number of Members	Nailed ⁽³⁾		1/2" Dia. Through Bolt ⁽¹⁾			5/8" Dia. Through Bolt ⁽¹⁾		
	3 rows 16d Sinks @ 12" o.c.	4 rows 16d Sinks @ 12" o.c.	3 rows @ 24" o.c. staggered	3 rows @ 18" o.c. 6" staggered	3 rows @ 12" o.c. 4" staggered	3 rows @ 24" o.c. 8" staggered	3 rows @ 18" o.c. 6" staggered	3 rows @ 12" o.c. 4" staggered
	3 rows 16d Sinks @ 12" o.c.	4 rows 16d Sinks @ 12" o.c.	3 rows @ 24" o.c. staggered	3 rows @ 18" o.c. 6" staggered	3 rows @ 12" o.c. 4" staggered	3 rows @ 24" o.c. 8" staggered	3 rows @ 18" o.c. 6" staggered	3 rows @ 12" o.c. 4" staggered
2	705	940	755	1010	1515	840	1120	1685
3 ⁽²⁾	525	705	565	755	1135	630	840	1260
4 ⁽⁴⁾	use bolt schedule		505	670	1010	560	745	1120

1. Design values apply to common bolts that conform to ANSI/ASME standard B18.21-1981 (ASTM A307 Grades A&B, SAE J429 Grades 1 or 2, or higher). A washer not less than a standard cut washer shall be between the wood and the bolt head and between the wood and the nut. The distance from the edge of the beam to the bolt holes must be at least 2" for 1/2" bolts and 2 1/2" for 5/8" bolts. Bolt holes shall be the same diameter as the bolt.
2. The nail schedules shown apply to both sides of a 3-member beam.
3. 16d box nails = 0.135" diameter x 3.5" length, 16d sinker nails = 0.148" diameter x 3.25" length.
4. 7" wide beams must be top-loaded or loaded from both sides (lesser side shall be no less than 25% of opposite side).

Top-Loaded Applications			
For top-loaded beams and beams with side loads less than shown in Side-Loaded Applications table above:			
Plies	Depth	Nailing ⁽²⁾	Maximum Uniform Load From One Side
(2) 1 3/4" plies	Depths 11 7/8" & less	2 rows 16d box/sinker nails @ 12" o.c.	400 plf
	Depths 14" - 18"	3 rows 16d box/sinker nails @ 12" o.c.	600 plf
	Depth = 24"	4 rows 16d box/sinker nails @ 12" o.c.	800 plf
(3) 1 3/4" plies ⁽¹⁾	Depths 11 7/8" & less	2 rows 16d box/sinker nails @ 12" o.c.	300 plf
	Depths 14" - 18"	3 rows 16d box/sinker nails @ 12" o.c.	450 plf
	Depth = 24"	4 rows 16d box/sinker nails @ 12" o.c.	600 plf
(4) 1 3/4" plies	Depths 18" & less	2 rows 1/2" bolts @ 24" o.c., staggered	335 plf
	Depth = 24"	3 rows 1/2" bolts @ 24" o.c., staggered every 8"	505 plf
(2) 3 1/2" plies	Depths 18" & less	2 rows 1/2" bolts @ 24" o.c., staggered	855 plf
	Depth 20" - 24"	3 rows 1/2" bolts @ 24" o.c., staggered every 8"	1285 plf

1. The nail schedules shown apply to both sides of a 3-member beam.
2. 16d box nails = 0.135" diameter x 3.5" length, 16d sinker nails = 0.148" diameter x 3.25" length.
3. Beams wider than 7" must be designed by the engineer of record.
4. All values in these tables may be increased by 15% for snow-load roofs and by 25% for non-snow load roofs where the building code allows.
5. Use allowable load tables or BC Calc® software to size beams.
6. An equivalent specific gravity of 0.5 may be used when designing specific connections with Versa-Lam®.
7. Connection values are based upon the NDS, 2018 Edition.
8. FastenMaster TrussLOK®, Simpson Strong-Tie SDW or SDS, and USP WS screws may also be used to connect multiple member Versa-Lam® LVL beams, contact Boise Cascade EWP Engineering for further information.

Designing Connections For Multiple Versa-Lam® LVL Members

When using multiple ply Versa-Lam® LVL beams to create a wider member, the connection of the plies is as critical as determining the beam size. When side loaded beams are not connected properly, the inside plies do not support their share of the load and thus the load-carrying capacity of the full member decreases significantly. The following is an example of how to size and connect a multiple-ply Versa-Lam® LVL floor beam.

Given: Beam shown below is supporting residential floor load (40 psf live load, 10 psf dead load) and is spanning 16'-0". Beam depth is limited to 14".

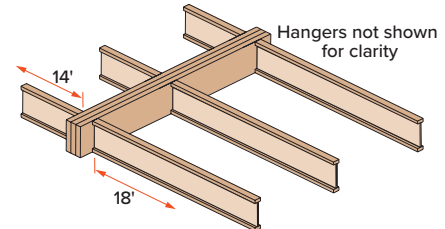

Find: A multiple 1 3/4" ply Versa-Lam® LVL that is adequate to support the design loads and the member's proper connection schedule.

1. Calculate the tributary width that beam is supporting:
 $14' / 2 + 18' / 2 = 16'$
2. Use PLF tables on pages 28-30 of your region's specifier guide or BC Calc® to size beam.
A Triple Versa-Lam® LVL 2.1 3100 1 3/4" x 14" is found to adequately support the design loads
3. Calculate the maximum plf load from one side (the right side in this case).
Max. Side Load = $(18' / 2) \times (40 + 10 \text{ psf}) = 450 \text{ plf}$
4. Go to the Multiple Member Connection Table, Side-Loaded Applications, 1 3/4" Versa-Lam® LVL, 3 members.
5. The proper connection schedule must have a capacity greater than the max. side load:

Nailed: 3 rows 16d sinks @ 12" o.c.
525 plf is greater than 450 plf OK
Bolts: 1/2" diameter 2 rows @ 12" staggered:
755 plf is greater than 450 plf OK



GUÍA DE INSTALACIÓN DE ESTE PARA PRODUCTOS EN MADERA DE INGENIERÍA



Calidad y rendimiento garantizado para toda la vida

Boise Cascade garantiza que sus productos de BCI® Joist, Versa-Lam®, y ALLJOIST® se acatan a nuestras especificaciones, estarán libres de defectos de material y fábrica, y satisfacen o exceden nuestras especificaciones de rendimiento para la vida normal y esperada de la estructura, cuando sean correctamente almacenados, y cuando se instalen y usen según nuestra guía de instalación.

Boise Cascade no ha evaluado los efectos de cualquier presión o aplicaciones tóxicas o tratamientos en su vigas BCI®, Versa-Lam® y los productos ALLJOIST®.

Para información sobre productos de ingeniería en madera de Boise Cascade, incluyendo términos y condiciones de venta, garantías y descargas de responsabilidad, visite nuestra página de internet en el www.BC.com/ewp

Para localizar a su distribuidor de productos de ingeniería en madera de Boise Cascade más cercano, llame al **1-800-232-0788**.

BCI® Joists

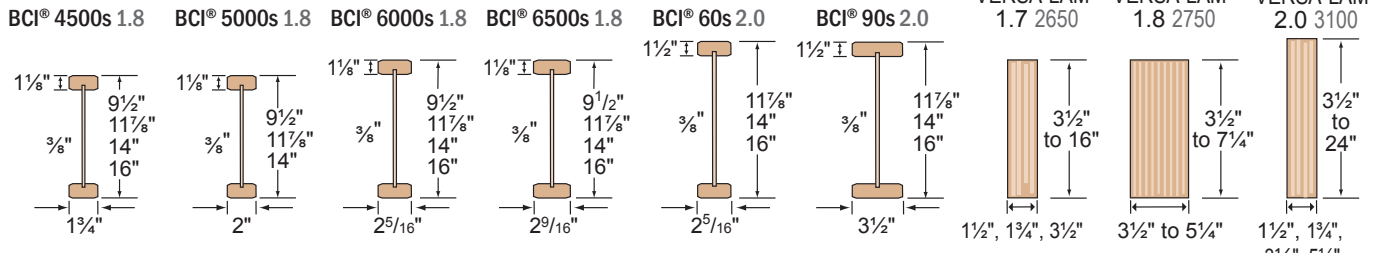

Product depths offered are listed below the product name. BCI® 60 and 90 deep depths are available from White City. Es posible que el producto no esté disponible. Infórmese sobre disponibilidad con un representante de Boise Cascade. Los productos BCI y VERSA-LAM deben ser instalados en aplicaciones de uso en seco solamente, de acuerdo a sus reportes de evaluación ECC ESR

ADVERTENCIA

LOS SIGUIENTES USOS NO SE PERMITEN

<p>NO ranure ni perforo vigas sin la aprobación del departamento de ingeniería de Boise Cascade EWP.</p>	<p>NO corte más allá del borde interior del soporte.</p>	<p>NO apoye la viga en el alma (panel).</p>
<p>NO corte los orificios demasiado cerca de los soportes o muy juntos.</p> <p>Vea la tabla de ubicación y tamaño de orificios para calcular tamaño y espaciamiento.</p>	<p>NO clave menos de 1/2 pulgadas del borde de la viga.</p> <p>NO use clavos comunes 16d.</p> <p>Use clavos 8d o clavos 10d/16d de caja.</p>	<p>NO corte ni ranure el reborde.</p> <p>Ver detalles para techo y piso en esta hoja respecto a las maneras permitidas para cortar el reborde.</p>
<p>NO camine sobre las vigas hasta que estén correctamente sujetadas.</p> <p>NO cargue la viga con más peso del que permite el diseño.</p> <p>NO amontone materiales de construcción en las vigas no sujetadas.</p>	<p>NO INSTALE la lengüeta del entarimado del piso al ras con la Boise Cascade rimboard de un grosor de 0 1 pulgada o 1 1/16 pulgadas (lengüeta OK usando Boise Cascade rimboard de grosor de 0 más de 1/8 pulgadas).</p> <p>Entarimado para piso T&G</p> <p>Recorte la lengüeta de entarimado de 1/8 pulgadas sin tener en cuenta el grosor del rimboard.</p> <p>Recorte la lengüeta al ras con el borde.</p> <p>Boise Cascade rimboard de un grosor de 1 pulgada o 1 1/16 pulgadas</p>	<p>NO martillar en la red a menos que retire los agujeros de no-caut.</p> <p>NO martille en la brida.</p>

Advertencia de Seguridad

NO PERMITA QUE LOS TRABAJADORES CAMINEN SOBRE LAS BCI® JOISTS HASTA QUE NO SE HAYAN INSTALADO TODOS LOS COLGADORES, BCI® RIM JOISTS (VIGAS DE BORDE BCI®), RIMBOARDS (TABLAS DE BORDE), BCI® BLOCKING PANELS (PANELES DE BLOQUEO BCI®), ARRIOSTRAMIENTO EN "X" Y LÍNEAS DE SOPORTE TEMPORAL 1X4 TAL COMO QUEDA ESPECIFICADO ABAJO. PUEDEN RESULTAR ACCIDENTES SERIOS POR FALTA DE ATENCIÓN AL ARRIOSTRAMIENTO (SOPORTE) CORRECTO DURANTE LA CONSTRUCCIÓN. LOS ACCIDENTES PUEDEN EVITARSE BAJO CIRCUNSTANCIAS NORMALES, SI SE OBSERVAN LAS SIGUIENTES PAUTAS:

- Construya una pared arriostrada a los extremos del recuadro o instale permanentemente los primeros ocho pies de BCI® Joists y el primer plano de entarimado. De otra forma, se puede clavar un entarimado provisional en los primeros cuatro pies de BCI® Joists en el extremo del recuadro.

- Todos los colgadores BCI® rim joists, rimboards, BCI® blocking panels y arriostramiento en "X", deben estar completamente instalados y correctamente clavados conforme se vaya acomodando cada BCI® Joist.
- Se deben instalar líneas de refuerzo provisionales de 1x4, a una distancia máxima de ocho pies en centro conforme se vayan acomodando BCI® Joists adicionales. Clave las líneas de refuerzo al área ya entarimada, o a la pared de extremo arriostrada, y a cada BCI® Joist con dos clavos 8d.
- Los extremos de voladizos deben estar sujetos temporalmente por líneas de refuerzo en los rebordes superiores e inferiores.
- Enderece las BCI® Joists a una alineación de menos de 1/2 pulgada de variación de la alineación justa antes de sujetar las líneas de refuerzo y el entarimado.
- Remueva las líneas de refuerzo temporal sólo conforme sea necesario para instalar el entarimado permanente.
- El no instalar el arriostramiento provisional puede resultar en que las vigas se encorven de lado o se volteen bajo una carga ligera de construcción.
- No apile materiales de construcción (entarimado, muro en seco - drywall, etc.) en el medio de los tramos entre las BCI® Joists. Póngase en contacto con Ingeniería Boise Cascade EWP para información de almacenaje apropiado y apuntalamiento.

INFORMES DE EVALUACIÓN DEL CÓDIGO DE CONSTRUCCIÓN:

Informes de evaluación del código de construcción para BCI® Joists

- ICC-ES®/APA® ESR-1336 (IBC, IRC)

Informes de evaluación del código de construcción para Versa-Lam® LVL

- ICC-ES®/APA® ESR-1040 (IBC, IRC)

Referente al rendimiento del piso

Las expectativas y opiniones de propietarios de vivienda varían enormemente debido a la naturaleza subjetiva de evaluar un nuevo piso. La comunicación con el usuario final para determinar sus expectativas es crítica. La vibración es por lo general la causa de la mayoría de las quejas. La instalación de un arriostado lateral puede ayudar; sin embargo, puede ocurrir que rechine si no se instala correctamente. Disminuir el espacio entre las vigas no afectará mucho la percepción del rendimiento del piso. Los métodos en uso más comunes para aumentar el rendimiento y reducir la vibración de sistemas de pisos de madera,

consisten en aumentar la profundidad de la viga, limitar desviaciones de viga, pegar y atornillar un subsuelo más grueso, a ranura y lengüeta, instalar las vigas verticalmente plomadas con soportes de carga nivelados, e instalar un techo directamente fijado a los rebordes de fondo de las vigas.

Las tablas de tramos de piso enlistadas abajo, ofrecen tres diferentes opciones de rendimiento, basadas en los requerimientos del propietario de la vivienda.

Profundidad de viga	Serie de viga BCI [®]	★★★ TRES ESTRELLAS ★★★					★★★★ CUATRO ESTRELLAS★★★★					PRECAUCIÓN ★ Rigidez mínima permitida por el Código ★ PRECAUCIÓN				
		La desviación de Carga Viva limitada a L/480: El estándar de la industria común y comunidad del diseño para vigas de piso residencial es 33% más rígido que el mínimo de código L/360. Sin embargo, el rendimiento del piso todavía puede ser un problema en ciertas aplicaciones, sobre todo con vigas de 9½" y 11⅞" pulgadas de profundidad sin un techo directamente adherido.					La desviación de Carga Viva limitada a L/960+: Además de proporcionar un piso que es 100% más rígido que el piso de tres estrellas, la experiencia en el campo ha sido incorporada en los valores para proveer un piso de un nivel de rendimiento superior para el propietario de vivienda más exigente.					La desviación de Carga Viva limitada a L/360: Los pisos que cumplen con el criterio mínimo L/360 del código de construcción son estructuralmente aptos para llevar las cargas especificadas; sin embargo, hay un riesgo mucho más alto de que surjan problemas con el rendimiento del piso. Esta tabla sólo deberá ser usada para aplicaciones en las que el rendimiento del piso no sea una preocupación.				
		12" o.c.	16" o.c.	19.2" o.c.	24" o.c.	32" o.c.	12" o.c.	16" o.c.	19.2" o.c.	24" o.c.	32" o.c.	12" o.c.	16" o.c.	19.2" o.c.	24" o.c.	32" o.c.
9½"	4500s 1.8	16'-11"	15'-6"	14'-8"	13'-7"	11'-9"	11'-6"	11'-6"	10'-0"	10'-0"	9'-7"	18'-9"	16'-8"	15'-3"	13'-7"	11'-9"
	5000s 1.8	17'-6"	16'-0"	15'-2"	14'-1"	12'-5"	11'-6"	11'-6"	10'-0"	10'-0"	9'-11"	19'-4"	17'-9"	16'-4"	14'-7"	12'-5"
	6000s 1.8	18'-2"	16'-8"	15'-8"	14'-8"	13'-4"	11'-6"	11'-6"	10'-0"	10'-0"	10'-0"	20'-2"	18'-5"	17'-5"	15'-9"	13'-8"
	6500s 1.8	18'-8"	17'-1"	16'-1"	15'-0"	13'-8"	11'-6"	11'-6"	10'-0"	10'-0"	10'-0"	20'-8"	18'-11"	17'-10"	16'-7"	14'-3"
11⅞"	4500s 1.8	20'-0"	18'-4"	17'-3"	15'-5"	13'-4"	15'-6"	14'-3"	13'-5"	12'-6"	11'-4"	21'-10"	18'-11"	17'-3"	15'-5"	13'-4"
	5000s 1.8	20'-9"	19'-0"	17'-11"	16'-7"	13'-4"	15'-6"	14'-9"	13'-11"	12'-11"	11'-9"	23'-0"	20'-4"	18'-6"	16'-7"	13'-4"
	6000s 1.8	21'-7"	19'-8"	18'-7"	17'-4"	14'-10"	15'-6"	15'-4"	14'-5"	13'-5"	12'-1"	23'-10"	21'-10"	20'-0"	17'-11"	14'-10"
	6500s 1.8	22'-2"	20'-3"	19'-2"	17'-10"	14'-10"	16'-0"	15'-10"	14'-11"	13'-10"	12'-7"	24'-6"	22'-5"	21'-1"	18'-10"	14'-10"
	60s 2.0	23'-7"	21'-6"	20'-4"	18'-11"	16'-4"	18'-0"	16'-9"	15'-9"	14'-8"	13'-3"	26'-1"	23'-10"	22'-6"	21'-0"	16'-4"
	90s 2.0	26'-7"	24'-3"	22'-10"	21'-3"	19'-4"	19'-0"	18'-10"	17'-8"	16'-5"	14'-10"	29'-5"	26'-10"	25'-3"	23'-6"	19'-4"
14"	4500s 1.8	22'-9"	20'-7"	18'-9"	16'-9"	13'-11"	17'-10"	16'-3"	15'-4"	14'-3"	13'-0"	23'-10"	20'-7"	18'-9"	16'-9"	13'-11"
	5000s 1.8	23'-7"	21'-7"	20'-2"	18'-0"	13'-11"	18'-6"	16'-10"	15'-11"	14'-9"	13'-5"	25'-7"	22'-1"	20'-2"	18'-0"	13'-11"
	6000s 1.8	24'-6"	22'-5"	21'-2"	19'-6"	15'-5"	19'-2"	17'-6"	16'-6"	15'-4"	13'-11"	27'-1"	23'-11"	21'-10"	19'-6"	15'-5"
	6500s 1.8	25'-2"	23'-0"	21'-8"	20'-2"	15'-5"	19'-8"	17'-11"	16'-11"	15'-8"	14'-3"	27'-9"	25'-2"	22'-11"	20'-6"	15'-5"
	60s 2.0	26'-9"	24'-5"	23'-0"	21'-5"	16'-4"	20'-11"	19'-0"	17'-11"	16'-7"	15'-1"	29'-7"	27'-0"	25'-6"	21'-10"	16'-4"
	90s 2.0	30'-1"	27'-5"	25'-10"	24'-0"	19'-6"	23'-6"	21'-4"	20'-0"	18'-6"	16'-9"	33'-3"	30'-4"	28'-7"	26'-0"	19'-6"
16"	4500s 1.8	25'-2"	22'-0"	20'-1"	17'-11"	14'-1"	19'-9"	18'-0"	17'-0"	15'-10"	14'-1"	25'-5"	22'-0"	20'-1"	17'-11"	14'-1"
	6000s 1.8	27'-0"	24'-9"	23'-4"	20'-10"	15'-9"	21'-2"	19'-4"	18'-2"	16'-11"	15'-4"	29'-6"	25'-6"	23'-4"	20'-10"	15'-9"
	6500s 1.8	27'-9"	25'-4"	23'-11"	21'-1"	15'-9"	21'-9"	19'-9"	18'-8"	17'-4"	15'-8"	30'-8"	26'-11"	24'-6"	21'-1"	15'-9"
	60s 2.0	29'-7"	27'-0"	25'-6"	21'-10"	16'-4"	23'-2"	21'-1"	19'-10"	18'-5"	16'-4"	32'-8"	29'-10"	27'-4"	21'-10"	16'-4"
	90s 2.0	33'-4"	30'-4"	28'-7"	26'-2"	19'-7"	26'-0"	23'-7"	22'-2"	20'-6"	18'-7"	36'-10"	33'-7"	31'-8"	26'-2"	19'-7"

- Los valores de las tablas están basados en cargas para piso residencial de 40 libras de carga viva por pie cuadrado y 10 libras por pie cuadrado de carga muerta (12 libras por pie cuadrado de carga muerta para BCI[®] 90s 2.0 Joists).
- Los valores de los tramos asumen que entarimado de madera laminada (plywood)/paneles de fibras orientadas reforzadas (clasificados OSB) de mínimo 23/32 pulgadas se encuentran pegados y clavados a vigas para la acción compuesta (las vigas espaciadas a 32 pulgadas en centro requieren entarimado tasado para tal espaciamiento – entarimado de madera laminada/paneles de fibras orientadas reforzadas OSB de 7/8 pulgadas).
- Los valores de la tabla representan las aplicaciones de tramo simple o múltiple más conservadoras. Analyze multiple span joists with BC Calc[®] sizing software if the length of any span is less than half the length of an adjacent span.

- Los valores de la tabla son la máxima distancia despejada permitida entre soportes.
- Los valores de la tabla asumen largos mínimos de soporte sin refuerzo del alma para profundidades de viga de 16 pulgadas y menos.
- Floor tile will increase dead load and may require specific deflection limits, contact Boise Cascade EWP Engineering for further information.
- Esta tabla fue diseñada para uso con una variedad de aplicaciones. Puede ser posible exceder las limitaciones de esta tabla, analizando una aplicación específica con el programa BC Calc[®] para medidas.

(Los valores marcados en tono más oscuro, no satisfacen los requisitos del Código de Construcción de Carolina del Norte. Ver la tabla de TRES ESTRELLAS cuando los tramos exceden los 20 pies.)

One-Hour Fire Resistance Assembly

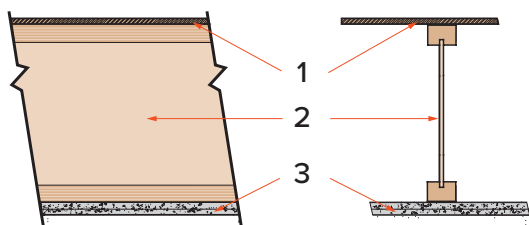

ICC-ES[®]/APA[®] ESR-1336

FIRE ASSEMBLY COMPONENTS

- Min. 23/32" thick tongue and groove sheathing (exterior glue), installed with long edge perpendicular to joist length, staggered one joist spacing with adjacent sheets, and glued to joists with construction adhesive.
- BCI[®] Joists at 24" o.c. or less.
- Two layers 5/8" Type X or two layers 1/2" Type C gypsum board, installed per Figures 2 or 3 of ICC-ES[®]/APA[®] ESR-1336.

SOUND ASSEMBLY COMPONENTS

When constructed with resilient channels

- Add carpet & pad to fire assembly:
- Add 3½" glass fiber insulation to fire assembly:
- Add an additional layer of minimum 5/8" sheathing and 9½" glass fiber insulation to fire assembly:

STC=54	IIC=68	or
STC=55	IIC=46	or
STC=61	IIC=50	

See the US version of the Boise Cascade Fire Design & Installation Guide for specific assembly information and other fire resistive options or contact your local Boise Cascade representative.

NOTA

La figura inferior muestra varios usos sugeridos para los productos de Boise Cascade EWP. No pretende mostrar una casa real en construcción.

NO SE REQUIERE ARRIOSTRADO (PUENTEO) DEL PUNTO MEDIO ENTRE SOPORTES DEL PISO PARA LOS BCI® JOISTS

PARA ESTABILIDAD DE INSTALACIÓN
Instale líneas de refuerzo temporales (1x4 mínimo) centradas a 8 pies, máximo. Sujete en cada viga con un mínimo de 2 clavos 8d.

La madera de dimensión no es adecuada para uso como tabla de orilla en los sistemas de piso BCI®.

F01 F02

BCI® rim joist. Ver los detalles del piso a continuación.

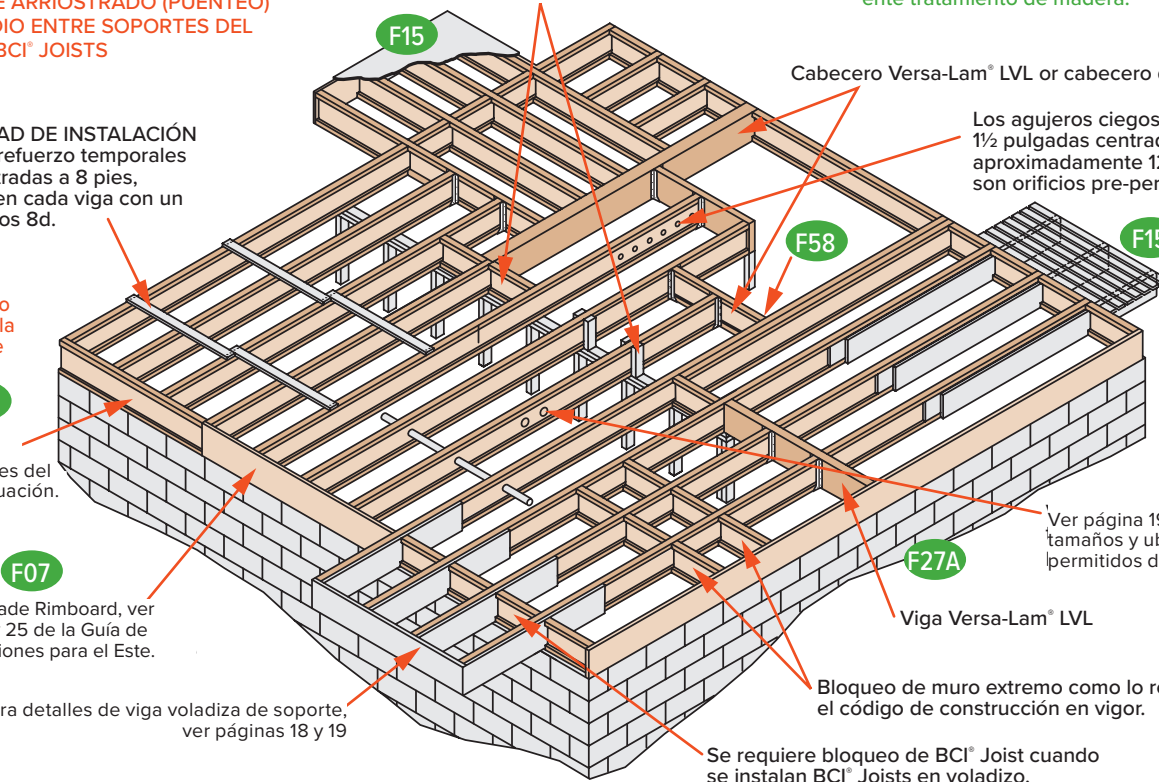

Boise Cascade Rimboard, ver páginas 6 y 25 de la Guía de Especificaciones para el Este.

F07

Para detalles de viga voladiza de soporte, ver páginas 18 y 19

F06 F09

Se requiere bloqueo de BCI® Joist o bloque 2x4 de presión a cada lado cuando se esté apoyando por encima un muro de carga.

Al instalar productos EWP de Boise Cascade con madera tratada, use sólo conectores/ sujetadores que estén aprobados para uso con el correspondiente tratamiento de madera.

Cabecero Versa-Lam® LVL or cabecero de BCI® Joist.

Los agujeros ciegos de 1/2 pulgadas centrados a aproximadamente 12 pulgadas son orificios pre-perforados.

F58

F15

Ver página 19 para tamaños y ubicación permitidos de agujeros.

F27A

Viga Versa-Lam® LVL

Bloqueo de muro extremo como lo requiere el código de construcción en vigor.

Se requiere bloqueo de BCI® Joist cuando se instalan BCI® Joists en voladizo.

BCI® Joists — Detalles de armadura de pisos

DETALLES DE SOPORTE DE LOS EXTREMOS

F07

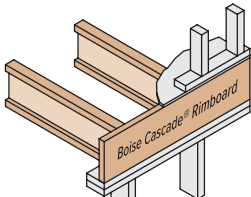

Clave Boise Cascade Rimboard a BCI® Joists con clavo 8d en cada reborde.

Madera aserrada en tamaños corrientes no es adecuada para uso como rim board con BCI® Joists.

F07A

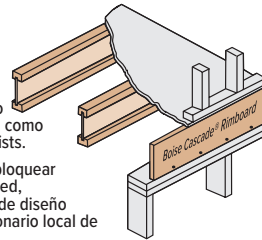

Madera aserrada en tamaños corrientes no es adecuada para uso como rim board con BCI® Joists. Puede ser necesario bloquear perpendicular a la pared, consultar profesional de diseño de registro y / o funcionario local de construcción.

F07B

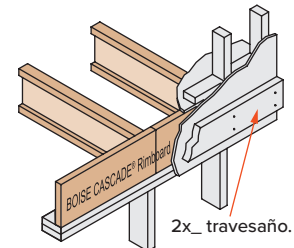

2x_ travesaño.

F02

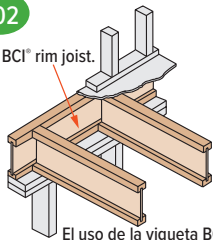

BCI® rim joist.

El uso de la vigueta BCI® requiere una pared de 2x6 para un rodamiento de vigueta mínimo.

F01

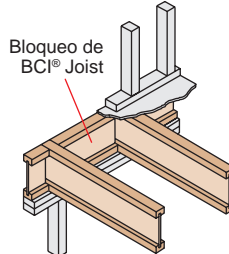

Bloqueo de BCI® Joist

F27A

Colgador de reborde superior o colgador de viga de montaje de cara.

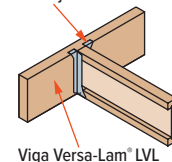

Viga Versa-Lam® LVL

F52

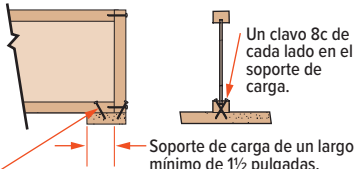

Un clavo 8c de cada lado en el soporte de carga.

Soporte de carga de un largo mínimo de 1 1/2 pulgadas.

Para limitar partir el reborde, comience clavando al menos 1 1/2 pulgadas a partir del extremo. Los clavos puede que se tengan que colocar en un ángulo para limitar que se parta la placa de apoyo.

F08

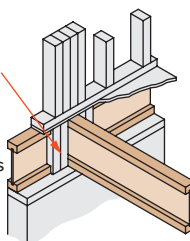

Posicione un bloque sólido entre los postes superiores al soporte inferior.

F03

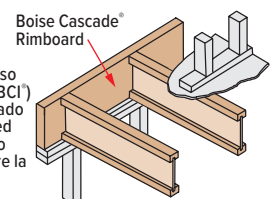

Boise Cascade® Rimboard

Nota: La viga de piso BCI® (viga de piso BCI®) debe estar conectada para cargar la pared superior cuando no esté montada sobre la pared inferior.

Se requiere bloqueo debajo de los paneles de pared arriostrados y paredes de corte, consulte al profesional de diseño de registro.

DETALLES PARA SOPORTE INTERMEDIO

F06 Pared de carga superior (montada sobre la pared inferior).
Bloqueo de BCI® Joist.

F05 Aplicación de paneles estructurales (cuando sea necesario).
Se requiere bloqueo de BCI® Joist para el voladizo.
Para el voladizo de soporte de carga, consulte las páginas 8 y 9 de la guía del especificador. La elevación en el tramo posterior será considerada en todos los diseños de voladizo.

F14 Refuerzo de viga en corte en pendiente
BCI® Joist Refuerza del corte de pendiente
El detalle abajo restore el valor original del esqueleto/reacción a cortar el extremo de la BCI® Joist. BCI® Joist no será utilizado como lazo de la tensión del collar o de la viga.
2 x 6 min. rafter. Rafter shall be supported by ridge beam or other upper bearing support.
Profundidad mínima de talón (vea tabla abajo)
Profundidad máxima de viga 16 pul.

F09 El bloqueo puede ser requerido en soportes intermedios para el diafragma de piso de acuerdo al IRC en áreas de actividad sísmica alta, consultar al oficial de construcción local.
Pared de carga superior (montada sobre la pared inferior).
Bloqueo de 2x.
1/16 pul.

Double Squash Block Vertical Load [lb/ft]				
Size	Joist Spacing [in]			
	12	16	19.2	24
2x4	4463	3347	2789	2231
2x6	7013	5259	4383	3506

- Squash blocks are to be in full contact with upper floor and lower wall plate.
- Capacities shown are for a double squash blocks at each joist, SPF or better.

2x blocking required at bearing (not shown for clarity).
2 3/32" min. plywood/OSB rated sheathing as reinforcement. Install reinforcement with face grain horizontal. Install on both sides of the joist, tight to bottom flange. Leave minimum 1/4" gap between reinforcement and bottom of top flange. Apply construction adhesive to contact surfaces and fasten with 3 rows of min. 10d box nails at 6" o.c. Alternate nailing from each side and clinch.

Soporte de pared de extremo	Profundidad mínima de talón					
	Inclinado del techo					
	6/12	7/12	8/12	9/12	10/12	12/12
2 x 4	4 3/8"	4 5/16"	4 1/4"	4 1/4"	4 1/4"	4 1/4"
2 x 6	3 3/8"	3 3/16"	2 5/16"	2 3/4"	2 9/16"	2 1/4"

F10 Bloque de respaldo (mínimo 12 pulgadas de ancho). Sujete con 10 clavos 10d.
Colgador de viga.
Bloque de relleno. Sujete con 10 clavos 10d.
Se requiere bloque de respaldo donde la carga del soporte colgante del reborde superior exceda 250 libras. Instale firmemente al reborde superior.

F58 Conexión de BCI® Joist doble (viga doble)
Web Filler Nailing See TN IJ-13 for joist specific schedule.
Filler Block (if required) See TN IJ-13 for requirements.
• Filler block not required when all loads are top loaded and evenly applied to each ply (except BCI® 90 and AJS® 25, 30). Side loads and/or uneven top loads require filler block.
• See Boise Cascade Technical Note IJ-13 for further information.
• Fasten floor sheathing to each ply per diaphragm nailing schedule.

SOPORTE LATERAL

- BCI® Joists shall be laterally supported at the ends with hangers, rimboard, BCI® rim joist or blocking panels. BCI® blocking panels or rimboard are required at cantilever supports.
- Blocking may be required at intermediate bearings for floor diaphragm per IRC in high seismic areas, consult local building official.

LONGITUD MÍNIMA DE SOPORTE PARA BCI® JOISTS

- Minimum end bearing: 1 1/2" for all BCI® Joists. 3 1/2" is required at cantilever and intermediate supports.
- Mayor longitud de soporte permite valores de reacción más altos. Vea el informe de la evaluación del código de construcción o el programa de software BC Calc®.

REQUISITOS DE CLAVADO

- BCI® rim joist, rim board o panel de cierre a BCI® Joist:
 - Bordes o panel de cierre de un grosor de 1 5/16 pulgadas o menos 2 clavos 8d, uno en el reborde superior y otro en el reborde inferior.
 - BCI® 4500s/5000s rim joist: 2 clavos de caja 10d, uno en el reborde superior y otro en el reborde inferior.
 - BCI® 6000s/60s rim joist: 2 clavos de caja 16d, uno en el reborde superior y otro en el reborde inferior.
 - BCI® 6500s/90s rim joist: Clave en X el reborde superior a la viga de borde con 2 clavos de caja 10d, uno por cada lado del reborde.
- BCI® rim joist, rim board o panel de bloqueo BCI® al soporte:
 - Mínimo 8d clavos centrados a 6 pulgadas por IRC®.
 - Cuando se use para transferencia de fuerza de empuje, siga las especificaciones del diseñador del edificio.
- BCI® joist al soporte:
 - 2 clavos 8d, uno por cada lado del alma, ubicados a un mínimo de 1 1/2 pulgadas del extremo de la BCI® Joist para evitar que se parta.

- Entarimado a BCI® Joist:
 - Clavar residencial preceptivo de enfundar de piso requiere los clavos comunes de 8d a 6" o.c. en los bordes y 12" o.c. en el campo Table IRC® R602.3(f).
 - Vea el clavo admisible más cercano que espacia los límites en atrás entrepaño para diafragma de piso que clava especificado en el espaciamento mas cerca que IRC®.
 - El máximo espaciamento de clavo para la estabilidad lateral mínima: 18" para BCI® 4500s y 5000s, 24" para mayor BCI® serie de vigas.
 - Grapas de calibre 14 pueden reemplazar las uñas 8d, si las grapas penetran en la viga durante un mínimo de 1 pulgada.
 - Los tornillos de madera pueden ser aceptables; para más información, póngase en contacto con el oficial encargado del código local de construcción y/o Boise Cascade EWP Engineering.

DIMENSIONES PARA BLOQUES DE RESPALDO Y DE RELLENO

Serie	Grosor de bloque de respaldo	Grosor de bloque de relleno
4500s 1.8	paneles de madera de 5/8 o 3/4 pul.	2 paneles de madera de 5/8 pul. o 2x_ pul.
5000s 1.8	paneles de madera de 3/4 o 7/8 pul.	2 paneles de madera de 3/4 pul. o 2x_ pul.
6000s 1.8	paneles de madera de 1 1/8 o dos paneles de madera de 1/2 pul.	2x_ + 7/16 pul. o panel de madera del 1/2 pul.
6500s 1.8	paneles de madera de 1 1/8 o dos paneles de madera de 3/8 pul.	2x_ + 5/8 pul. o panel de madera del 3/4 pul.
60s 2.0	paneles de madera de 1 1/8 o dos paneles de madera de 1/2 pul.	2x_ + 7/16 pul. o panel de madera del 1/2 pul.
90s 2.0	2x_ madera de construcción	Doble 2x_ madera de construcción

- Corte los bloques de respaldo y de relleno a una profundidad máxima igual a la profundidad del alma menos una 1/4 pulgada para

REQUISITOS PARA EL REFUERZO DEL ALMA

- Vea en la página 19 "Requisitos para el refuerzo del alma."
- PROTEJA LAS BCI® JOISTS DEL TIEMPO (CLIMA)
 - Las BCI® Joists están diseñadas sólo para aplicaciones que proporcionan protección permanente del tiempo (clima). Los bultos de BCI® Joists deben almacenarse cubiertas, elevadas del suelo y con espaldadores.

BCI® RIM JOISTS Y BCI® BLOQUEO

Profundidad [pul.]	Serie	Capacidad de carga vertical [plf]	
		No W.S. ⁽¹⁾	W.S. ⁽²⁾
9 1/2"	4500s 1.8, 5000s 1.8, 6000s 1.8, 6500s 1.8	2300	N/A
	4500s 1.8, 5000s 1.8, 6000s 1.8, 6500s 1.8	2150	N/A
11 1/8"	60s 2.0, 90s 2.0	2500	N/A
	4500s 1.8, 5000s 1.8, 6000s 1.8, 6500s 1.8	2000	N/A
14"	60s 2.0, 90s 2.0	2400	N/A
	4500s 1.8, 6000s 1.8, 6500s 1.8	1900	2500
16"	60s 2.0, 90s 2.0	2300	2700

- (1) No web stiffeners required.
- (2) Web stiffeners required at each end of blocking, values not applicable for rim joists.
- N/A: Not applicable.

Espaciamento mínimo de clavado				
BCI® Joists		Todas las BCI® Joists		
		Clavado perpendicular a las líneas de pegamento (cara ancha)		Clavado paralelo a líneas de pegamento (cara angosta)
		Espaciamento centrado a (pulgadas)	Extremo de viga (pulgadas)	Extremo de viga (pulgadas)
Tamaño de clavo				
8d de caja	(0.113"ø x 2.5")	2	1 1/2	4
8d común	(0.131"ø x 2.5")	2	1 1/2	3
10d & 12d de caja	(0.128"ø x 3", 3.25")	2	1 1/2	3
16d de caja	(0.135"ø x 3.5")	2	1 1/2	3
10d & 12d común & 16d grabador	(0.148"ø x 3", 3.25")	3	2	4
16d común	(0.162"ø x 3.5")	3	2	4

- Si se aplica más de una fila de clavos, las filas habrán de contrabalancearse por un mínimo de 1/2 pulgada.
- Los conectores Simpson Strong-Tie A35 pueden colocarse al lado de BCI® bridas de vigas de los años 60 y 90 solamente. Use clavos como especifica el Simpson Strong-Tie; no coloque conectores a ambos lados de un reborde en la misma posición.

BCI® Joists

Clavado perpendicular a las líneas de pegamento (cara ancha)

Clavado paralelo a las líneas de pegamento (cara angosta)

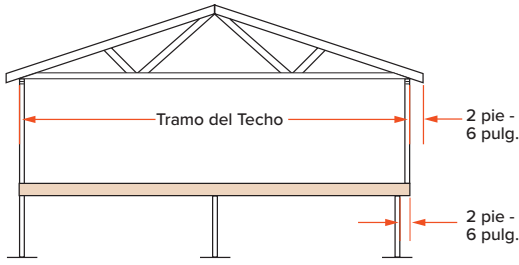

REFUERZO DE MADERA LAMINADA/ENTABLADO OSB (si así se requiere de acuerdo a la tabla de viga volada de soporte)

- Madera laminada de mínimo $2\frac{3}{32}$ x 48 pulgadas de largo/entablado tasado OSB debe igualar la profundidad completa de la BCI Joist. Clávese a la BCI Joist con clavos 8d a 6 pulgadas en centro y clávese con 4 clavos 8d en el bloque de respaldo. Cuando se refuerzan ambos lados, alterne los clavos para evitar que se parta la madera. Instalar con la fibra de cara horizontal
- The tables on page 19 assume a wall weight of 100 plf, in addition to the roof loading shown. Applications with loading that exceeds the loads shown shall be analyzed with BC Calc® software.
- Estos requisitos suponen una carga de pared de 100 PLF. Es posible que se requiera soporte adicional para otras cargas, consulte el software BC Calc®.

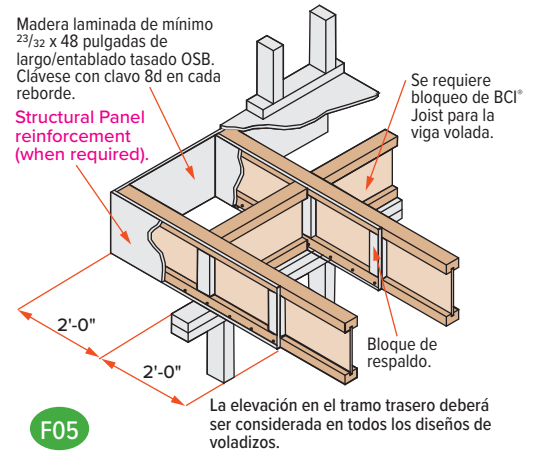

- Las tablas y detalles que se muestran en esta guía indican el tipo de refuerzos, si hicieran falta, que se requieren para vigas voladas de soporte de carga de hasta un largo máximo de 2 pies, 0 pulgadas. Vigas voladas de un largo mayor de 2 pies, 0 pulgadas no se pueden reforzar. **No obstante, vigas voladas más largas con cargas menores puede que se permitan sin llevar refuerzo. Analice aplicaciones específicas con el programa de software de BC Calc®.**

Detalles de voladizo con pared sin carga

BCI® Joists are intended only for applications that provide permanent protection from the weather. Impervious moisture barrier systems shall be detailed and installed in details F15A and F15B in accordance with 2018 IBC® Sections 107.2.5 and 110.3.6.

Sujete el 2x8 mínimo al BCI® Joist clavando a través del bloque de respaldo y alma de la viga con 2 filas de clavos 10d, centrados a 6 pulgadas. Use clavos 16d con BCI® 90s 2.0 joists. Remache todos los clavos.

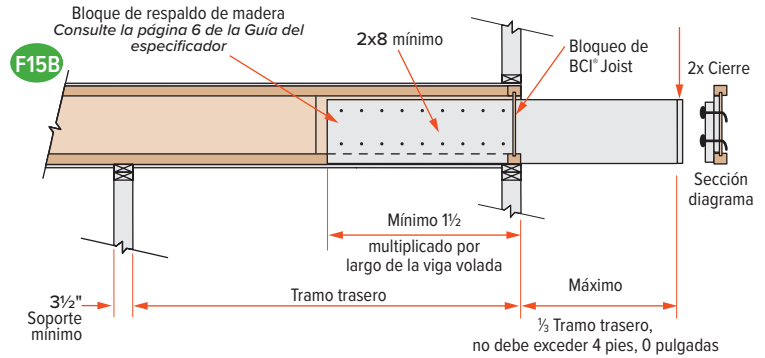
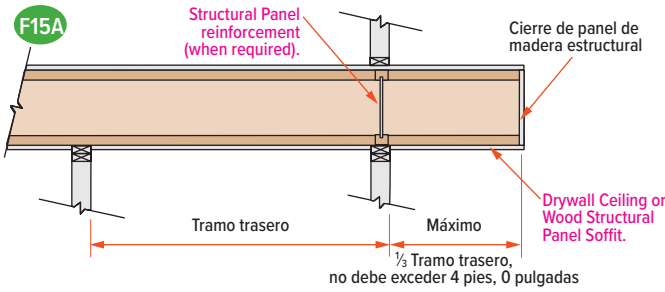

- Analizar la condición de voladizo BCI® Joist con el software BC Calc®.

- Loading shall not exceed 60 psf live load and 10 psf dead load. At least three joist members shall be present and spaced at 24" o.c. or less.
- Lumber joist shall be No. 2 Dense Southern Pine, No.1/No.2 SPF, No.2 Hem-fir, or No.2 Douglas fir, or higher grade.
- Provide positive drainage, durable materials, and venting as required in 2018 IBC Sections 2304.12.2.5 and 2304.12.2.6. Lumber joist shall be sloped.

Requisitos para refuerzo del alma

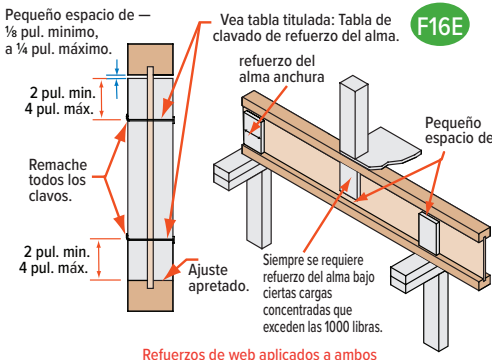

Notas

- Los refuerzos del alma son opcionales, excepto como queda especificado en lo siguiente.
- Siempre se requiere refuerzo del alma en los colgadores que no se extienden a proporcionar soporte al reborde superior de la BCI® Joist. Se pueden requerir refuerzos del alma con ciertos tipos de colgadores con sesgo o ángulo o para lograr valores de elevación. Vea los requisitos de instalación del fabricante del colgador.
- Siempre se requieren refuerzos del alma en ciertas aplicaciones de techo. Ver "Detalles de armadura de techos" en la página 22-23.
- Siempre se requiere refuerzo del alma bajo ciertas cargas concentradas que exceden las 1000 libras. Instale los refuerzos de panel pegados al reborde superior en esta situación. Siga las especificaciones de clavado para soportes de carga intermedios.
- Web stiffeners may be cut from structural rated wood panels, engineered rimboard or 2x lumber (BCI® 90s only).
- For Structural Capacity: Web stiffeners needed to increase the BCI® Joist's reaction capacity at a specific bearing location.
- Lateral Restraint in Hanger: Web stiffeners required when hanger does not laterally support the top flange (e.g., adjustable height hangers). Web stiffeners may be of multiple thickness (e.g., BCI® 6500,s double 1/2" panel OK).
- Se pueden usar los refuerzos del alma para aumentar los valores de reacción permitidos. Vea la guía de especificaciones o el programa de software BC Calc®.

Refuerzo del alma de panel estructural			
Serie	Para la capacidad estructural (Grosor mínimo)	Restricción lateral en percha	Anchura mínima
4500s 1.8	5/8"	5/8"	2 ⁵ / ₁₆ "
5000s 1.8	5/8"	3/4"	2 ⁵ / ₁₆ "
6000s 1.8	3/4"	7/8"	2 ⁵ / ₁₆ "
6500s 1.8	3/4"	1" or 1 ¹ / ₈ "	2 ⁵ / ₁₆ "
60s 2.0	3/4"	7/8"	2 ⁵ / ₁₆ "
90s 2.0	madera de construcción 2x4 (vertical)		

Tabla de clavado de refuerzo del alma

Serie de Viga	Profundidad de Viga	Ubicación del soporte de carga	
		Final/Extremo	Intermedio
4500s 1.8	9 1/2"	2-8d	2-8d
	11 7/8"	2-8d	3-8d
	14"	2-8d	5-8d
	16"	2-8d	6-8d
5000s 1.8	9 1/2"	2-8d	2-8d
	11 7/8"	2-8d	3-8d
	14"	2-8d	5-8d
	16"	2-8d	6-8d
6000s 1.8	9 1/2"	2-8d	2-8d
	11 7/8"	2-8d	3-8d
	14"	2-8d	5-8d
	16"	2-8d	6-8d
6500s 1.8	9 1/2"	2-8d	2-8d
	11 7/8"	2-8d	3-8d
	14"	2-8d	5-8d
	16"	2-8d	6-8d
60s 2.0	11 7/8"	2-8d	3-8d
	14"	2-8d	5-8d
	16"	2-8d	6-8d
90s 2.0	11 7/8"	3-16d	3-16d
	14"	5-16d	5-16d
	16"	6-16d	6-16d

BCI® Joists se fabrican con agujeros ciegos de perforado redondo de 1½ pulgadas en el alma centrados a aproximadamente 12 pulgadas

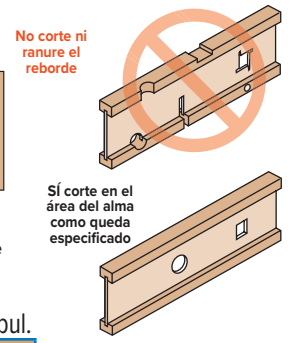
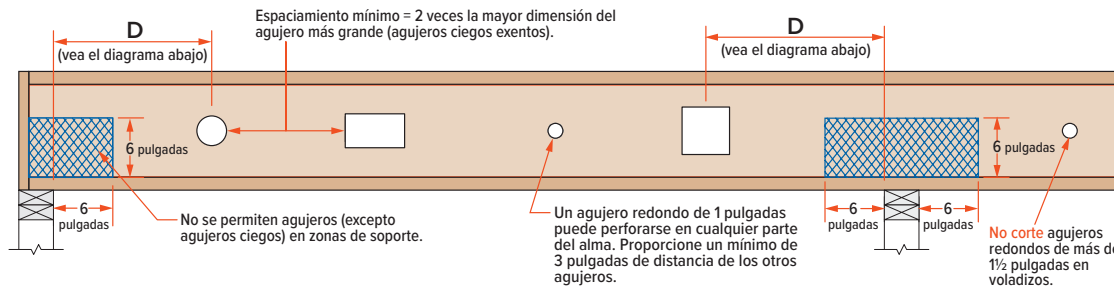

Distancia mínima del soporte, en la lista siguiente de la tabla, es necesario para todos los agujeros mayores que 1½ pul.

Distancia mínima (D) de cualquier soporte a la línea central del agujero																
Diámetro de agujero redondo (pul.)		2	3	4	5	6	6½	7	8	8¾	9	10	11	12	13	
Lado de agujero rectangular (pul.)		-	-	-	3	5	6	7	-	-	-	-	-	-	-	
Any 9½" Joist	Span [ft]	8	1'-0"	1'-1"	1'-5"	2'-1"	2'-9"	3'-1"	3'-5"							
		12	1'-0"	1'-2"	2'-2"	3'-2"	4'-2"	4'-8"	5'-2"							
		16	1'-0"	1'-7"	2'-11"	4'-3"	5'-7"	6'-3"	6'-11"							
Any 11¾" Joist	Span [ft]	8	1'-0"	1'-1"	1'-5"	1'-10"	2'-4"	2'-7"	2'-10"	3'-4"	3'-9"					
		12	1'-0"	1'-4"	2'-1"	2'-10"	3'-7"	3'-11"	4'-3"	5'-0"	5'-8"					
		16	1'-0"	1'-10"	2'-10"	3'-9"	4'-9"	5'-3"	5'-9"	6'-9"	7'-7"					
Any 14" Joist	Span [ft]	8	1'-0"	1'-1"	1'-2"	1'-3"	1'-8"	1'-10"	2'-1"	2'-6"	2'-10"	2'-11"	3'-4"	3'-8"		
		12	1'-0"	1'-1"	1'-3"	1'-10"	2'-6"	2'-10"	3'-1"	3'-9"	4'-3"	4'-4"	5'-0"	5'-7"		
		16	1'-0"	1'-1"	1'-8"	2'-6"	3'-4"	3'-9"	4'-2"	5'-0"	5'-8"	5'-10"	6'-8"	7'-5"		
Any 16" Joist	Span [ft]	8	1'-0"	1'-1"	1'-2"	1'-2"	1'-3"	1'-3"	1'-3"	1'-7"	1'-11"	2'-0"	2'-5"	2'-9"	3'-2"	3'-7"
		12	1'-0"	1'-1"	1'-2"	1'-2"	1'-3"	1'-6"	1'-10"	2'-5"	2'-11"	3'-0"	3'-7"	4'-2"	4'-9"	5'-4"
		16	1'-0"	1'-1"	1'-2"	1'-2"	1'-8"	2'-1"	2'-6"	3'-3"	3'-11"	4'-0"	4'-10"	5'-7"	6'-4"	7'-2"
Any 16" Joist	Span [ft]	20	1'-0"	1'-1"	1'-2"	1'-2"	2'-1"	2'-7"	3'-1"	4'-1"	4'-11"	5'-1"	6'-0"	7'-0"	8'-0"	8'-11"
		24	1'-0"	1'-1"	1'-2"	1'-4"	2'-6"	3'-1"	3'-9"	4'-11"	5'-11"	6'-1"	7'-3"	8'-5"	9'-7"	10'-9"

- Selección una fila de la tabla basada en la profundidad y tramo actual de la viga, redondeando al siguiente tramo en la tabla.
- Revise la fila hasta encontrar la columna que muestre el diámetro de agujero redondo o de lado rectangular apropiado.
- Use el lado más largo de un agujero rectangular. El valor de la tabla indica la distancia más corta permitida de la línea central del agujero a la línea central del soporte más cercano.
- Se puede recortar el alma entero. **NO CORTE** los rebordes. Los agujeros se aplican o a las vigas sencillas o múltiples en condiciones de miembros repetitivos.
- Para agujeros múltiples, la cantidad de alma sin cortar entre los agujeros debe ser igual a un mínimo del doble del diámetro (o del lado más largo) del agujero más grande.
- Los agujeros ciegos redondos de 1½ pulgadas en el alma pueden perforarse usando un trozo corto de tubería metálica y un martillo.
- Los agujeros pueden posicionarse verticalmente en cualquier parte del alma. La viga puede acomodarse con los agujeros de 1½ pulgadas volteados hacia arriba o hacia abajo.
- Esta tabla fue diseñada para aplicarla a las condiciones de diseño cubiertas en otras tablas de esta publicación. Use el programa BC CALC® para verificar otros tamaños de agujeros o agujeros bajo otras condiciones de diseño. Puede que sea posible exceder las limitaciones de esta tabla analizando una aplicación específica con el programa de software BC CALC®.

Large Rectangular Holes in BCI® Joists

Hole size table based on maximum uniform load of 40 psf live load and 10 psf dead load, at maximum spacing of 24" on-center.

Single Span Joist

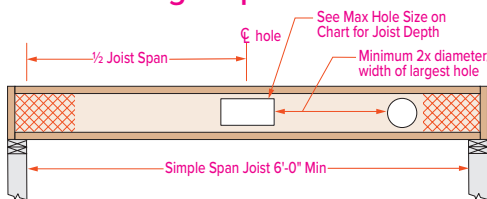

Joist Depth	Maximum Hole Size	
	Simple Span	Multiple Span
9½"	6" x 14"	6" x 12"
11¾"	7" x 16" 8" x 15"	8" x 12"
14"	9" x 16" 10" x 15"	8" x 15"
16"	9" x 18" 11" x 16"	10" x 14"

Notes:
Additional holes may be cut in the web provided they meet the specifications as shown in the hole distance chart shown above or as allowed using BC Calc® sizing software.

Multiple Span Joist

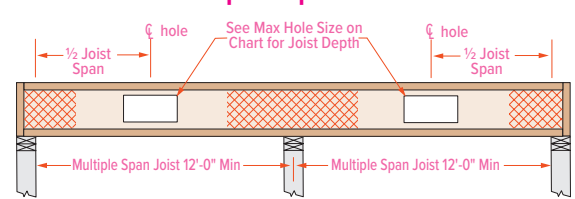

Larger holes may be possible for either Single or Multiple span joists; use BC Calc® sizing software for specific analysis.

Notes

- No se permiten agujeros cuadrados ni rectangulares.
- Pueden taladrarse agujeros redondos con un serrucho de agujeros en cualquier área sombreada de la viga.
- La distancia horizontal entre agujeros contiguos debe ser por lo menos el doble de la medida del agujero más grande.
- No taladre más de tres agujeros de acceso en una sección de cuatro pies de cualquier viga.
- El tamaño máximo permitido para agujero redondo es de:

Profundidad de viga	Diámetro máximo de agujero
5½"	¾"
7¼"	1"
9¼ pul. y más	2"

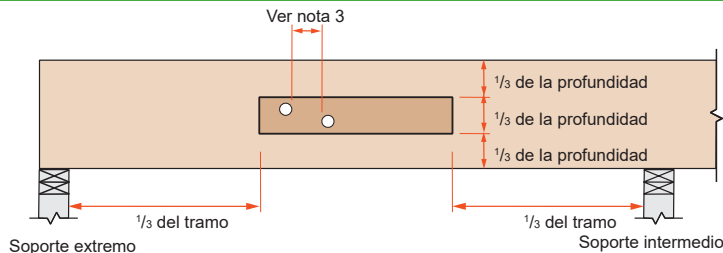

- Estas limitaciones se aplican sólo a los agujeros taladrados para acceso de fontanería o alambrado. El tamaño y la ubicación de los agujeros taladrados para fiadores están regulados por las disposiciones de las "Las especificaciones nacionales de diseño para la construcción de madera (National Design Specifications for Wood Construction)".
- Beams deflect under load. Size holes to provide clearance where required.
- Esta tabla de agujeros es válida sólo para vigas que soportan carga uniforme. Para vigas que soportan cargas concentradas o para vigas con agujeros más grandes, comuníquese con Ingeniería de Boise Cascade EWP.

Espaciado de uñas más cercano y permitido

Productos Versa-Lam® LVL Tamaño de clavo	Clavado paralelo a las líneas de pegamento (cara angosta) ⁽¹⁾						Clavado perpendicular a las líneas de pegamento (cara ancha)	
	Versa-Lam® LVL 1½"		Versa-Lam® LVL 1¾"		Versa-Lam® LVL 3½" & Wider		Todos los productos	
	Espaciamiento centrado (pulgadas)	Extremo de viga (pulgadas)	Espaciamiento centrado (pulgadas)	Extremo de viga (pulgadas)	Espaciamiento centrado (pulgadas)	Extremo de viga (pulgadas)	Espaciamiento centrado (pulgadas)	Extremo de viga (pulgadas)
8d de caja (0.113"Ø x 2.5")	3	1½	2	1	2	½	2	½
8d común (0.131"Ø x 2.5")	3	2	3	2	2	1	2	1
10d & 12d de caja (0.128"Ø x 3", 3.25")	3	2	3	2	2	1	2	1
16d de caja (0.135"Ø x 3.5")	3	2	3	2	2	1	2	1
10d & 12d común & 16d grabador (0.148"Ø x 3", 3.25")	4	3	4	3	2	2	2	2
16d común (0.162"Ø x 3.5")	6	4	6	3	2	2	2	2

- Acode y alterne las filas de clavos del entarimado y placa de asiento de la pared.
- Conectores Simpson Strong-Tie A35 y LPT4 pueden conectarse al lado de Versa-Lam® LVL. Use clavos de acuerdo a las especificaciones de Simpson Strong-Tie.

Productos Versa-Lam® LVL & Versa-Rim®

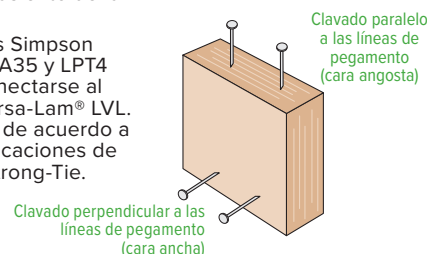

Notas de clavado

- Para grosor de 1¾ pulgadas y más, se permiten 2 filas de clavos (como para correa de metal) – (use desplazamiento horizontal mínimo de ½ pulgada entre las filas y alterne los clavos).

Características de Boise Cascade Rimboard

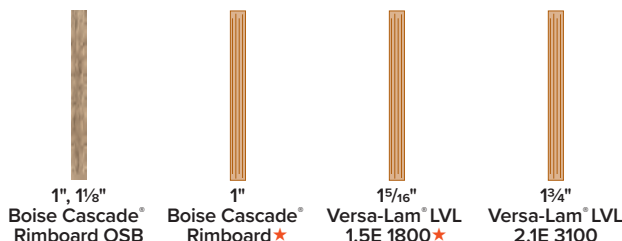

9½"
11⅝"
14"
16"

★ Es posible que el producto no esté disponible. Consulte con el proveedor o el representante de Boise Cascade para conocer la disponibilidad.

Producto	Capacidad de carga vertical		Máxima capacidad lateral del diafragma del piso [libras/pies]	Valores de diseño permitidos			
	Uniforme [plf]	Punto [lb]		Tensión flexional [lb/in²]	Módulo de elasticidad [lb/in²]	Cortante horizontal [lb/in²]	Compresión perpendicular a la fibra [lb/in²]
1" Boise Cascade® Rimboard ⁽²⁾ 1" Boise Cascade® Rimboard OSB ⁽²⁾	3300	3500	180	Capacidades de tramo limitadas, ver nota 2			
1½" Boise Cascade® Rimboard OSB ⁽²⁾	4400	3500	180	Capacidades de tramo limitadas, ver nota 2			
1½" Versa-Lam® LVL 1.4 1800 ⁽¹⁾	6000	4450	Permitido por el código de construcción para todos los diafragmas de piso armado de 2 pulgadas de grosor.	1800	1,400,000	225	525
1¾" Versa-Lam® LVL 2.0 3100 ⁽¹⁾	5700	4300	Permitido por el código de construcción para todos los diafragmas de piso armado de 2 pulgadas de grosor.	3100	2,000,000	285	750

Espaciamiento más cercano entre clavos permitido - Lado angosto [pul.]	Producto			
	1" Boise Cascade® Rimboard ⁽²⁾ 1" Boise Cascade® Rimboard OSB ⁽²⁾	1½" Boise Cascade® Rimboard OSB ⁽²⁾	1½" Versa-Lam® LVL 1.4 1800 ⁽¹⁾	1¾" Versa-Lam® LVL 2.1 3100 ⁽¹⁾
8d de caja (0.113"Ø x 2.5")	3	3	3	3
8d común (0.131"Ø x 2.5")	3	3	3	3
10d & 12d de caja (0.128"Ø x 3", 3.25")	Ver nota 2 para información sobre el clavado			
16d de caja (0.135"Ø x 3.5")				
10d & 12d común & 16d grabador (0.148"Ø x 3", 3.25")				
16d común (0.162"Ø x 3.5")				

Notas

- Ver ICC-ES®/APA® ESR-1040 para más información del producto.
- Ver rendimiento de Rim Boards, APA® Form No. W345N para información de producto adicional.

Las vigas BCI®, VERSA-LAM® y ALLJOIST® se deben almacenar, instalar y usar según esta Guía de Instalación, los códigos de construcción, y de forma no inconsistente con esta Guía de Instalación, y según las prácticas normales y usuales de construcción. Las vigas VERSA-LAM®, ALLJOIST® y BCI® deben ser envueltas, cubiertas, y elevadas del suelo en espaciadores a toda hora antes de ser instaladas. Las vigas VERSA-LAM®, ALLJOIST® y BCI® Joists están diseñadas para usos

que aseguran que no serán expuestas a la intemperie o a los elementos y en un ambiente libre de humedad de cualquier tipo, cualquier plaga, organismo o sustancia que descomponga o dañe la madera o las uniones de pegamento. El incumplimiento de las instrucciones para almacenamiento, uso o instalación correcta de las vigas VERSA-LAM®, ALLJOIST® y BCI® de acuerdo a la Guía de Instalación de Boise Cascade EWP, anulará la garantía limitada.

Vigas de techo BCI®

Detalles adicionales para armadura de pisos se encuentran disponibles a través del programa de software BC Framer®

PARA ESTABILIDAD DE INSTALACIÓN, Posicione líneas temporales de refuerzo (mínimo de 1x4), centradas a 8 pies máximo. Fijar con dos clavos 8d como mínimo en cada viga.

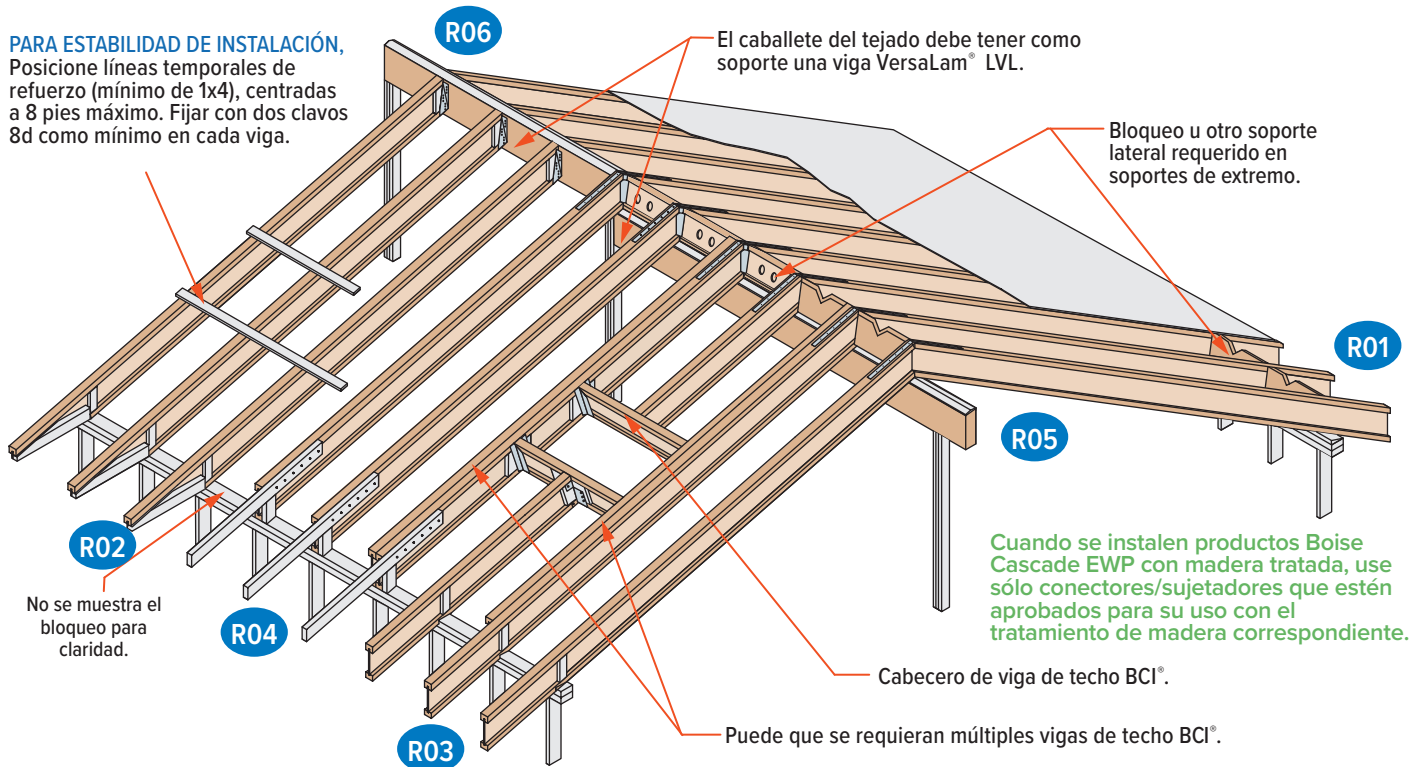

Advertencia de Seguridad

NO PERMITA TRABAJADORES EN BCI® JOISTS HASTA QUE NO SE HAYAN INSTALADO TODOS LOS COLGADORES, BCI® RIM JOISTS (VIGAS DE BORDE BCI®), RIMBOARDS (TABLAS DE BORDE), BCI® BLOCKING PANELS (PANELES DE BLOQUEO BCI®), ARRIOSTRAMIENTO EN "X" Y LÍNEAS DE SOPORTE TEMPORAL 1X4 TAL COMO QUEDA as ESPECIFICADO ABAJO.

ACCIDENTES SERIOS POR FALTA DE ATENCIÓN AL ARRIOSTRAMIENTO (SOPORTE) CORRECTO DURANTE LA CONSTRUCCIÓN. LOS ACCIDENTES PUEDEN EVITARSE BAJO CIRCUNSTANCIAS NORMALES, SI SE OBSERVAN LAS SIGUIENTES PAUTAS:

- Construya una pared arriostrada a los extremos del recuadro o instale permanentemente los primeros ocho pies de BCI® Joists y el primer plano de entarimado. De otra forma, se puede clavar un entarimado provisional en los primeros cuatro pies de BCI® Joists en el extremo del recuadro.
- Todos los colgadores BCI® rim joists, rimboards, BCI® blocking panels y arriostramiento en "X", deben estar completamente instalados y correctamente clavados conforme se vaya.
- Se deben instalar líneas de refuerzo provisionales de 1x4, a una distancia máxima de ocho pies en centro conforme se vayan acomodando BCI® Joists adicionales. Clave las líneas del puntal al área envainada o pared del final vigorizada, y a cada Viga BCI® con dos 8d clavos.
- Los extremos de voladizos deben estar sujetos temporalmente por líneas de refuerzo en los rebordes superiores e inferiores.
- Enderece las BCI® Joists a una alineación de menos de pulgada de variación de la alineación justa antes de sujetar las líneas de refuerzo y el entarimado.
- Remueva las líneas de refuerzo temporal sólo conforme sea necesario para instalar el entarimado permanente.
- El no instalar el arriostramiento provisional puede resultar en que las vigas se encorven de lado o se voltéen bajo una carga ligera de construcción.
- No apile materiales de construcción (entarimado, muro en seco – drywall, etc.) en el medio de los tramos entre las BCI® Joists. Póngase en contacto con Ingeniería Boise EWP para información de almacenaje apropiado y apuntalamiento.

BCI® Ceiling Joist (Viga de techo BCI®) con corte de bisel en el extremo (sólo para desvanes de acceso limitado)

La vigueta de BCI® no será utilizada pues collar/lazo de la tensión. El viga de la azotea será apoyado por la viga del canto o el otro soporte de rodadura superior.

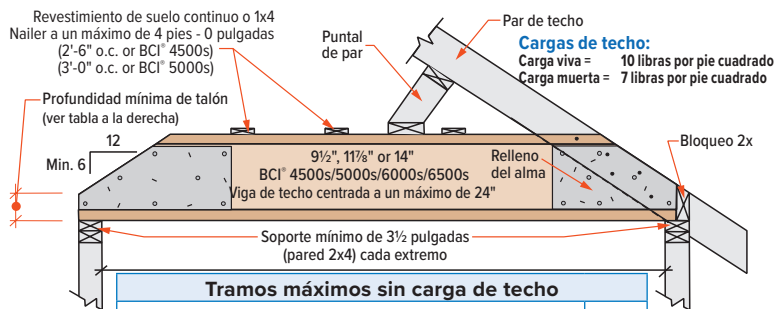

Tramos máximos sin carga de techo	
9 1/2" BCI 4500s 1.8 / 5000s 1.8 / 6000s 1.8 / 6500s 1.8	20'-0"
11 1/8" BCI 4500s 1.8 / 5000s 1.8 / 6000s 1.8 / 6500s 1.8	22'-6"
14" BCI 4500s 1.8 / 5000s 1.8 / 6000s 1.8 / 6500s 1.8	24'-6"

(Si existe carga de techo, vea las notas 2 y 3 de abajo)

Profundidad mínima de talón	Profundidad de viga	pared de extremo	
		2 x 4	2 x 6
9 1/2"	2 1/2"	1 1/2"	
11 1/8"	3 1/2"	2 1/2"	
14"	4 1/2"	3 1/2"	

Notas:

- 1) El detalle es para que se use sólo con vigas de techo sin acceso al espacio de desván.
- 2) La viga de techo debe ser diseñada para llevar toda la carga del techo transferida por los puntales de par como queda mostrado.
- 3) La reacción al extremo de la viga de techo BCI® no debe exceder 550 libras.
- 4) La inclinación de techo mínima es 6/12.
- 5) Clave la par al BCI® top flange (reborde superior BCI®) con clavos 1-10d de caja (3 pulgadas de largo).
- 6) El clavado de 1x4 debe ser continuo y clavado a la pared extrema apuntalada.
- 7) Instalar un refuerzo del alma en cada lado del BCI® Joist al extremo biselado. Clavar la par al BCI® Joist de acuerdo a los requisitos del código de construcción para la conexión de viga de techo a la par.

Detalles adicionales para armadura de techos se encuentran disponibles a través del programa de software BC Framer®

R01

Se requiere placa biselada de 2x para un sesgo de más de 1/4/12.

Se pueden usar conectores Simpson VPA o USP TMP o sus iguales, en lugar de la placa biselada para sesgos de 3/12 a 12/12.

R02

Bloqueo Rimboard/ Versa-Lam® LVL. Ventilación, cortada en V: 1/2 de longitud, 1/2 de profundidad

2x4 bloqueo para apoyo de sofito

2 pies - 6 pulg. max.

El reborde BCI® Joists puede ser cortado en pico de pájaro sólo al extremo inferior de la viga. Un BCI® Joist con corte de pico de pájaro debe soportar totalmente en la placa. Se requiere refuerzo de alma a cada lado. El reborde de fondo deberá estar totalmente soportado.

R03

Bloqueo Rimboard/ Versa-Lam® LVL Ventilación, cortada en V: 1/2 de longitud, 1/2 de profundidad

Ajuste apretado para estabilidad lateral.

2 pies - 6 pulg. max.

El reborde BCI® Joists puede ser cortado en pico de pájaro sólo al extremo inferior de la viga. Un BCI® Joist con corte de pico de pájaro debe estar soportado totalmente en la solera; se requiere refuerzo del alma por cada lado.

R04

Clavos 10d centrados a 6 pul.

2x4 por un lado para un máximo de 135 lpl. 2x6 por un lado para un máximo de 240 lpl.

Bloque de respaldo. Grosor de acuerdo a la correspondiente serie de BCI®.

Bloque de 2x.

Agujeros recortados en el bloqueo BCI® para ventilación.

4 pies - 0 pul. horiz.

2 pies - 6 pul. horiz.

R05

Correa apretadora Simpson o USP LSTA24, clavado de acuerdo al código de construcción en vigor.

Viga de soporte Versa-Lam® LVL.

BCI® bloqueo. Agujeros cortados para ventilación.

Lámina doble de madera biselada.

El bloqueo en ambos lados de la cresta puede ser necesario para la transferencia de cizallamiento por diseño profesional de registro.

R06

Correa Simpson o USP LSTA24 donde la pendiente supera el 7/12 (pueden ser necesarias correas para pendientes más bajas en zonas de viento alto). Clavado de acuerdo al código de construcción en vigor.

Viga de soporte Versa-Lam® LVL.

Lámina doble de madera biselada.

Simpson LSSUI o USP TMU colgador.

R07

Colgador de viga

Bloque de respaldo (de ancho mínimo de 12 pulgadas). Sujete con 10 clavos 10d.

Bloque de relleno. Clavar con 10 clavos 10d.

Se requiere bloque de respaldo donde la carga del colgador de viga exceda 250 libras. Instalar apretado a la brida superior.

R11

L (2 pies - 0 pulg. max.)

La doble viga puede ser requerida cuando L excede el espaciado de viga.

Bloqueo tal como se requiere.

Clave el voladizo a través del alma BCI®.

Voladizo de 2 pulgadas x tajado alrededor del reborde superior BCI®. El espaciado entre voladizos no debe ser mayor que 24 pulgadas en

El final de

DN05

No corte la viga en bisel más allá de la cara interior de la pared, para condiciones específicas que se muestran en detalles en la sección de "Armadura de pisos y techos" en esta guía.

NOTAS PARA DETALLES DE ARMADURA DE TECHOS

SOPORTE LATERAL

- BCI® Joists must be laterally supported at end supports (including supports adjacent to overhangs) with hangers, rimboard, or blocking (Versa-Lam® LVL, Boise Cascade Rimboard or BCI® Joist). Metal cross bracing or other x-bracing provides adequate lateral support for BCI® Joists, consult governing building code for roof diaphragm connection provisions.

LONGITUD MÍNIMA DE SOPORTE PARA BCI® JOISTS

- Minimum end bearing: 1 1/2" for all BCI® Joists. 3 1/2" is required at cantilever and intermediate supports.
- Mayor longitud de soporte permite valores de reacción más altos. Vea el informe de la evaluación del código de construcción o el programa de software BC Calc®.

REQUISITOS DE CLAVADO

- BCI® rim joist, rim board o panel de cierre a BCI® Joist:
 - Bordes o panel de cierre de un grosor de 1 5/16 pulgadas o menos 2 clavos 8d, uno en el reborde superior y otro en el reborde inferior.
 - BCI® 4500s/5000s rim joist: 2 clavos de caja 10d, uno en el reborde superior y otro en el reborde inferior.
 - BCI® 6000s/60s rim joist: 2 clavos de caja 10d, uno en el reborde superior y otro en el reborde inferior.
 - BCI® 6500s/90s rim joist: Clave en X el reborde superior a la viga de borde con 2 clavos de caja 10d, uno por cada lado del reborde.
- BCI® rim joist, rim board o panel de bloqueo BCI® al soporte:
 - Mínimo 8d clavos centrados a 6 pulgadas por IRC®.
 - Cuando se use para transferencia de fuerza de empuje, siga las especificaciones del diseñador del edificio.
- BCI® joist al soporte:
 - 2 clavos 8d, uno por cada lado del alma, ubicados a un mínimo de 1 pulgadas del extremo de la BCI® Joist para evitar que se parta.

- BCI® joist la cubierta:
 - Clavar residencial preceptivo de enfundar de piso residencial prescriptivo requiere 8 clavos comunes - centrados a 6 pul. en los bordes y - centrados a 12 pul. en el campo (IRC® Tabla R602.3(1)).
 - Vea el clavo admisible más cercano que espacia los límites en atrás entrepaño para diafragma de piso que clava especificado en el espaciamiento mas cerca que IRC® en página 17.
 - El máximo espaciamiento de clavo para la estabilidad lateral mínima: 18" para BCI® 4500s y 5000s, 24" para mayor BCI® serie de vigas.
 - Grapas de calibre 14 pueden reemplazar las uñas 8d, si las grapas penetran en la viga durante un mínimo de 1 pulgada.
 - Los tornillos de madera pueden ser aceptables; para más información, póngase en contacto con el oficial encargado del código local de construcción y/o Boise Cascade EWP Engineering.

DIMENSIONES PARA BLOQUES DE RESPALDO Y DE RELLENO

Serie	Grosor de bloque de respaldo	Grosor de bloque de relleno
4500s 1.8	paneles de madera de 3/4 o 1 pul.	2 paneles de madera de 3/8 pul. o 2x
5000s 1.8	paneles de madera de 3/4 o 7/8 pul.	2 paneles de madera de 3/4 pul. o 2x
6000s 1.8	paneles de madera de 1 1/8 o dos paneles de madera de 1/2 pul.	2x + 7/16 pul. o panel de madera del 1/2 pul.
6500s 1.8	paneles de madera de 1 1/8 o dos paneles de madera de 3/8 pul.	2x + 5/8 pul. o panel de madera del 3/4 pul.
60s 2.0	paneles de madera de 1 1/8 o dos paneles de madera de 1/2 pul.	2x + 7/8 pul. o panel de madera del 1/2 pul.
90s 2.0	2 x madera de construcción	Doble 2x madera de construcción

- Corte los bloques de respaldo y de relleno a una profundidad máxima igual a la profundidad del alma menos una pulgada para evitar un ajuste forzado.

REQUISITOS PARA EL REFUERZO DEL ALMA

- Vea en la página 19 "Requisitos para el refuerzo del alma."

PROTEGER LAS VIGAS BCI® DEL CLIMA

- Las BCI® Joists están diseñadas sólo para aplicaciones que proporcionan protección permanente del tiempo (clima). Los bultos de BCI® Joists deben almacenarse cubiertas, elevadas del suelo y con espaciadores.

INCLINACIÓN MÁXIMA

- A no ser que se especifique de otra forma, todos los detalles de techo son válidos para inclinaciones de 12 en 12 menos.

VENTILACIÓN

- Los agujeros pre-estampados de 1 pulgada con espaciamiento a 12 pulgadas en centro a lo largo de la BCI® Joist pueden abrirse y usados para ventilación. **Deeper joists that what is structurally needed may be advantageous in ventilation design.** Consulte con un experto en ventilación para requisitos específicos.

CORTES EN PICO DE PÁJARO

- En las BCI® Joists cortes de pico de pájaro pueden hacerse sólo en el soporte del extremo inferior. Las BCI® Joists con cortes de pico de pájaro pueden extenderse hasta 2 pies, 6 pulgadas más allá del soporte del extremo inferior. El reborde bajo debe descansar completamente en el soporte y no puede extenderse sobre la cara interior del soporte. Los soportes de extremos superiores e intermedios no deben cortarse en pico de pájaro.

SOPORTE EN PAREDES DE CONCRETO / MAMPOSTERIA

Proporcionar barrera de humedad y la sujeción lateral en el soporte.

Se requiere un espacio de aire de 1/2 pulgada entre el concreto y la madera.

B01

SOPORTE PARA CABECERO DE PUERTA O VENTANA

Instale tira de acuerdo al código, si la lámina superior no es continua sobre el cabecero.

Vigas que soportan el cabecero.

B02

CONNECTOR DE VIGA A VIGA

Verifique la capacidad de la percha con el fabricante de la percha.

B03

SOPORTE EN LA COLUMNA

Columna Versa-Lam® LVL.

columna conectores, consulte al profesional de diseño de registro.

B04

CORTE DE ASIENTO INCLINADO

Corte de asiento inclinado. No debe extenderse más allá de la cara interior del soporte.

El bloqueo no muestra para mayor claridad.

B06

CORTE BISELADO

DO NOT bevel cut Versa-Lam® LVL beyond inside face of wall without approval from Boise Cascade EWP Engineering or BC Calc® software analysis.

B07

VIGA A PARED DE MAMPOSTERÍA O CONCRETO

La placa superior de madera debe estar al ras con el interior de la pared.

Colgador.

Barrera de humedad entre concreto y madera.

B08

ARMAR LA VIGA EN LA PARED

Instale correa de acuerdo al código si la lámina superior no es continua.

B09

NOTAS PARA LA INSTALACIÓN

- Se deberá proporcionar un mínimo de 1/2 pulgada de espacio de aire entre la viga y espacio de la pared o barrera adecuada entre la viga y el concreto/mampostería.
- Deberá proporcionarse el soporte adecuado. Si no se muestra en los planos, por favor refiérase a tablas de carga en la Guía de Especificaciones de su región, páginas 28-30.
- Las vigas Versa-Lam® LVL están diseñadas para uso interior únicamente y deberían mantenerse secas lo máximo posible durante la construcción.
- Deberá proporcionarse apoyo lateral continuo a la parte superior de la viga (armadura de soporte lateral o superior).

Conectores de Múltiples Miembros

Aplicaciones con carga lateral							
Carga lateral uniforme máxima [libras por pie lineal – lpl]							
Número de miembros	Clavado ⁽³⁾		Perno pasante de 1/2 pulg. diámetro ⁽¹⁾		Perno pasante de 5/8 pulg. diámetro ⁽¹⁾		
	2 filas grabadores 16d, centrados a 12 pulgadas	3 filas grabadores 16d, centrados a 12 pulgadas	2 filas, centrados a 24 pulgadas, alternados	2 filas, centrados a 12 pulgadas, alternados	2 filas, centrados a 6 pulgadas, alternados	2 filas, centrados a 24 pulgadas, alternados	2 filas, centrados a 12 pulgadas, alternados
Versa-Lam® LVL de 1 3/4 pulgadas (profundidades de 18 pulgadas y menos)							
2	470	705	505	1010	2020	560	1120
3 ⁽²⁾	350	525	375	755	1515	420	840
4 ⁽³⁾	aplique plan de especificaciones para pernos		335	670	1345	370	745
Versa-Lam® LVL de 3 1/2 pulgadas							
2 ⁽³⁾	aplique plan de especificaciones para pernos		855	1715	N/A	1125	2250
Versa-Lam® LVL de 1 3/4 pulgadas (profundidades de 24 pulgadas y menos)							
Número de miembros	Clavado		Perno pasante de 1/2 pulg. diámetro ⁽¹⁾		Perno pasante de 5/8 pulg. diámetro ⁽¹⁾		
	3 filas grabadores 16d, centrados a 12 pulgadas	4 filas grabadores 16d, centrados a 12 pulgadas	3 filas, centrados a 24 pulgadas, 8 pul. alternados	3 filas, centrados a 12 pulgadas, 6 pul. alternados	3 filas, centrados a 6 pulgadas, 4 pul. alternados	3 filas, centrados a 24 pulgadas, 8 pul. alternados	3 filas, centrados a 12 pulgadas, 4 pul. alternados
2	705	940	755	1010	1515	840	1120
3 ⁽²⁾	525	705	565	755	1135	630	840
4 ⁽³⁾	aplique plan de especificaciones para pernos		505	670	1010	560	745

- Valores de diseño se aplican a pernos comunes que conforman a ANSI/ASME Standard B18.21-1981 (ASTM A307 Grados A & B, SAE J429 grados 1 o 2, o más alto). Una planchuela de perno, cuyo corte no sea más pequeño que el de una planchuela estándar, deberá estar entre la madera y la cabeza del tornillo y entre la madera y la tuerca. La distancia del borde de la viga a los orificios del perno debe ser al menos 2 pulgadas para pernos de 1/2 pulgada y 2 1/2 pulgadas para pernos de 5/8 pulgadas. Los orificios del perno deberán ser del mismo diámetro que la del perno.
- Las especificaciones de clavado mostradas se aplican a los dos lados de una viga de tres miembros.
- 16d clavos de la caja = 0.135 pul. diámetro x 3.5 pul. el largo, 16d clavos de la grabador = 0.148 pul. diámetro x 3.25 pul. el largo.
- Las vigas de 7 pulgadas deben tener carga superior o carga por ambos lados (El lado de carga lateral menor no deberá ser menos del 25% del lado opuesto).

El diseño de conexiones para miembros múltiples de Versa-Lam® LVL

Cuando se usen varias capas de vigas Versa-Lam® LVL para crear un miembro más ancho, la conexión de las capas es tan importante como la determinación del tamaño de la viga. Cuando las vigas con carga lateral no están correctamente conectadas, las capas internas no soportan su parte de la carga, disminuyendo así considerablemente la capacidad de carga del miembro total. Lo siguiente es un ejemplo de cómo determinar el tamaño y cómo conectar varias capas de vigas ersa-Lam® LVL para piso.

Hecho: La viga mostrada abajo soporta un piso residencial (con carga viva de 40 libras por pie cuadrado, 10 libras por pie cuadrado peso muerto), con una anchura de 16 pies, 0 pulgadas. La profundidad de la viga es limitada a 14 pulgadas.

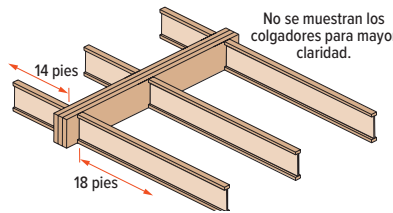

Encuentre: Una Versa-Lam® LVL de capas múltiples de 1 3/4 pulgadas que sea adecuada para soportar las cargas de diseño y las especificaciones indicadas para ese miembro.

Aplicaciones con carga superior

Para vigas con cargas superiores y vigas con cargas laterales menores a las que se muestran:

Capas	Profundidad	Clavado	Máxima carga uniforme por un lado
(2) capas de 1 3/4 pul.	Profundidad 11 1/8 pul. y menos	2 filas clavos grabadores/de caja 16d, centrados a 12 pulgadas	400 libras por pie lineal
	Profundidad 14 - 18 pul.	3 filas clavos grabadores/de caja 16d, centrados a 12 pulgadas	600 libras por pie lineal
	Profundidad = 24 pul.	4 filas clavos grabadores/de caja 16d, centrados a 12 pulgadas	800 libras por pie lineal
(3) capas de 1 3/4 pul. (2)	Profundidad 11 1/8 pul. y menos	2 filas clavos grabadores/de caja 16d, centrados a 12 pulgadas	300 libras por pie lineal
	Profundidad 14 - 18 pul.	3 filas clavos grabadores/de caja 16d, centrados a 12 pulgadas	450 libras por pie lineal
	Profundidad = 24 pul.	4 filas clavos grabadores/de caja 16d, centrados a 12 pulgadas	600 libras por pie lineal
(4) capas de 1 3/4 pul.	Profundidad 18 pul. y menos	2 filas pernos de 1/2 pul. centrados a 24 pul. y alternados	335 libras por pie lineal
	Profundidad = 24 pul.	3 filas pernos de 1/2 pul. centrados a 24 pul. y alternados cada 8 pulgadas	505 libras por pie lineal
(2) capas de 3 1/2 pul.	Profundidad 18 pul. y menos	2 filas pernos de 1/2 pul. centrados a 24 pul. y alternados	855 libras por pie lineal
	Profundidad 20 - 24 pul.	3 filas pernos de 1/2 pul. centrados a 24 pul. y alternados cada 8 pulgadas	1285 libras por pie lineal

- Calcule la anchura tributaria de la viga que soporta:
 $14 \text{ pies} / 2 + 18 \text{ pies} / 2 = 16 \text{ pies}$
- Use las tablas de PLF (libras por pie lineal) en las páginas 28-30 del guía de especificación de su región o BC Calc® para calcular el tamaño de la viga.
Una viga triple de 1 3/4 pulgadas x 14 pulgadas Versa-Lam® LVL 2.1 3100 ha demostrado ser adecuada para soportar las cargas de diseño.
- Calcule la máxima carga de libras por pie lineal (en este caso, el lado derecho).
Carga Lateral Máxima = $(18 \text{ pies} / 2) \times (40 + 10 \text{ por pie cuadrado}) = 450 \text{ libras por pie lineal}$
- Vea la Tabla de conexiones de miembros múltiples, Aplicaciones de carga lateral, Versa-Lam® LVL de 1 3/4 pulgadas, 3 miembros
- Las especificaciones para la conexión indicada deben tener una capacidad mayor a la máxima carga lateral:
Clavado: 3 filas de clavos grabadores 16d centrados a 12 pulgadas:
525 libras por pie lineal es mayor a 450 libras por pie lineal **CORRECTO**
Pernos: 1/2 pulgada de diámetro, 2 filas, centrados y alternados a 12 pulgadas:
755 libras por pie lineal es mayor a 450 por pie lineal **CORRECTO**
- Los valores de conexión están basados en NDS, 2018 la edición.
- Los FastenMaster TrussLok, Simpson Strong-Tie SDS y SDW, y tornillos USP WS también pueden ser usados para conectar múltiples miembros de vigas Versa-Lam® LVL, contacte a ingeniería de Boise Cascade EWP para información adicional.